

## Driving 3-Phase Brushless Motors

### 1.1 INTRODUCTION

*NOTE: Apex Precision Power has developed a MCU program with a soft start algorithm for driving motors with the Apex Precision Power SA303 and SA306. Download it free from the SA303 or SA306 product page at [www.Cirrus.com](http://www.Cirrus.com).*

When comparing the attributes of a brushless motor with those of its brush motor equivalent, the most notable difference is the reduction in size and weight for the brushless motor offering the same horsepower. What is less obvious is the absence of the familiar brush–commutator arrangement that has been at the heart of single-phase DC brush motors for over a century. The lack of a brush-commutator interface means brushless motors also exhibit lower acoustic noise, are virtually maintenance free and they simply last longer.

Despite their many advantages, price points for brushless motors have been the single greatest detractor from their gaining wide-spread acceptance. That is until recently. Like all new technology, it was only a matter of time until gradual price reductions reached a level where demand would begin to increase. Today the price differential between brushless versus brush can be as little as 10 percent.

Adding to the appeal of the brushless motor is the widening availability of microcontrollers with the special functions (routines) necessary to control the three-phase operation of brushless motors. Equally important, and more readily available, are IC drivers that deliver power to the motor and form the interface between the microcontroller and the brushless motor itself.

This application note is intended to help guide the development of brushless motor drive boxes and motor drive cards. These specialized designs include the microcontroller, the programmability and the driver – all in a single assembly.

Let's begin this discussion by looking at the primary difference between motors with brushes and those without – the use of commutation. Commutation refers to an on-going sequence of steps that specifies the application of volt-ages to the proper motor phases and imparts the desired motor rotation throughout each successive 360-degree revolution.

Brush-type DC motors use electromechanical commutation that is achieved via graphite brushes that contact a circular commutator mounted on the rotor. The motor is designed so that torque is maximized as the motor shaft rotates throughout each full 360-degree rotation. However, in a brushless motor, although there is sensorless commutation, it is usually performed by switching electronics that rely on devices such as Hall sensors. This arrangement is depicted in Figures 1 and 2. The Hall sensors feed back the position of the rotor at known instants to the control electronics. Brushless motors use what is commonly referred to as “inside out” commutation because their design is essentially that of a brush motor turned inside out. Although the stators in the motor are wound, the rotor is not. Instead it employs a permanent

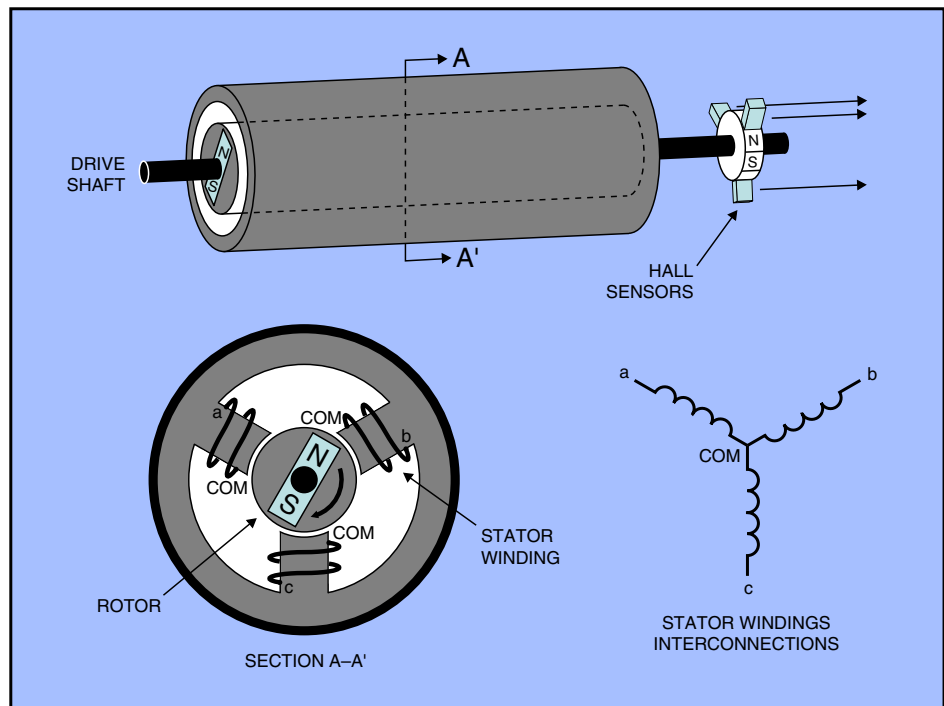

**Figure 1. A Brushless Motor** – Differs from a motor with brushes in that commutation is provided by sensors rather than the familiar brush-commutator arrangement found in a conventional DC motor with brushes.

magnet rotor. The magnetic attraction of the rotor to the revolving magnetic field is induced in the wound stator poles and develops the torque necessary to rotate the motor and drive the attached load. This scenario is depicted in Figure 1.

Also brushless motors are synchronous in behavior because the rotor rotates at the same frequency as the magnetic field developed by the stator windings. Thus they differ from single-phase, AC squirrel-cage motors in which 'slip' develops, causing the rotor to rotate at a slightly lower frequency than the rotating AC field, depending on the load. Thanks to the Hall sensors, the control circuitry always knows the exact moment to commute. Most brushless motor manufacturers supply motors with three Hall-effect position sensors. Each sensor delivers an alternating binary high and a binary low as the rotor turns. The three sensors are offset, as illustrated in Figure 1. Each sensor aligns with one of the fields developed by one of the wound stator poles. Note that as depicted in Figure 3, two windings are always energized while one winding is not.

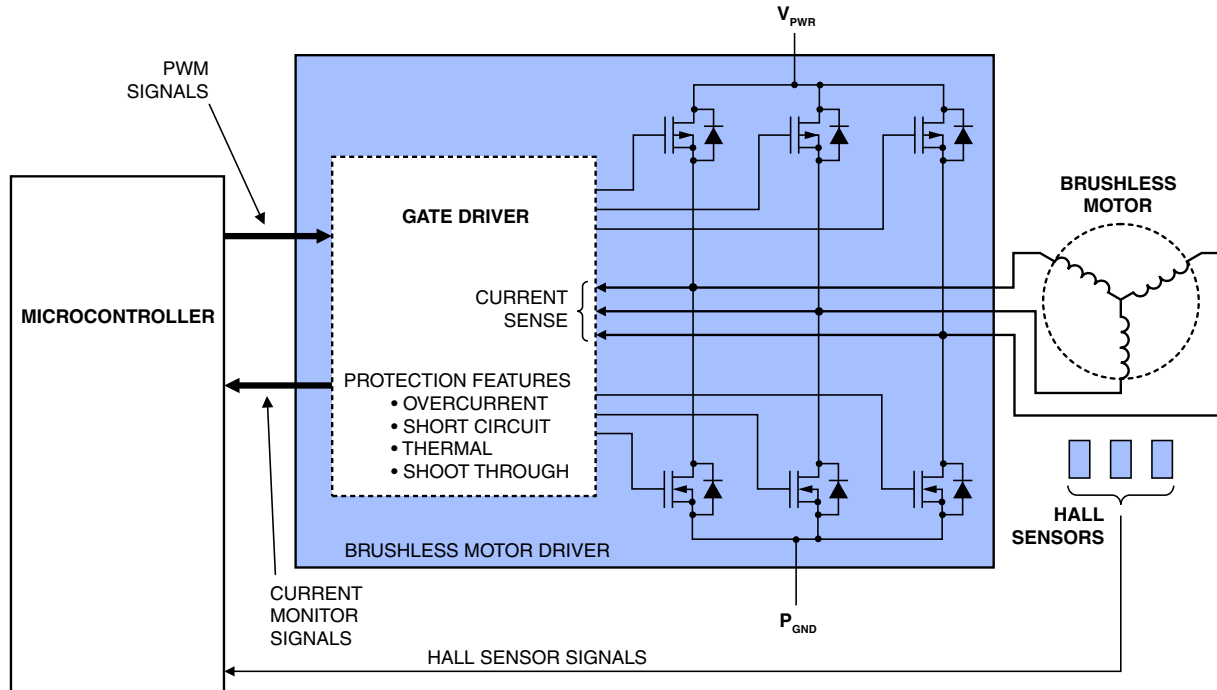

**Figure 2. Block Diagram** – A microcontroller and an Apex Precision Power Brushless Motor Driver provide the necessary functions to drive a brushless motor.

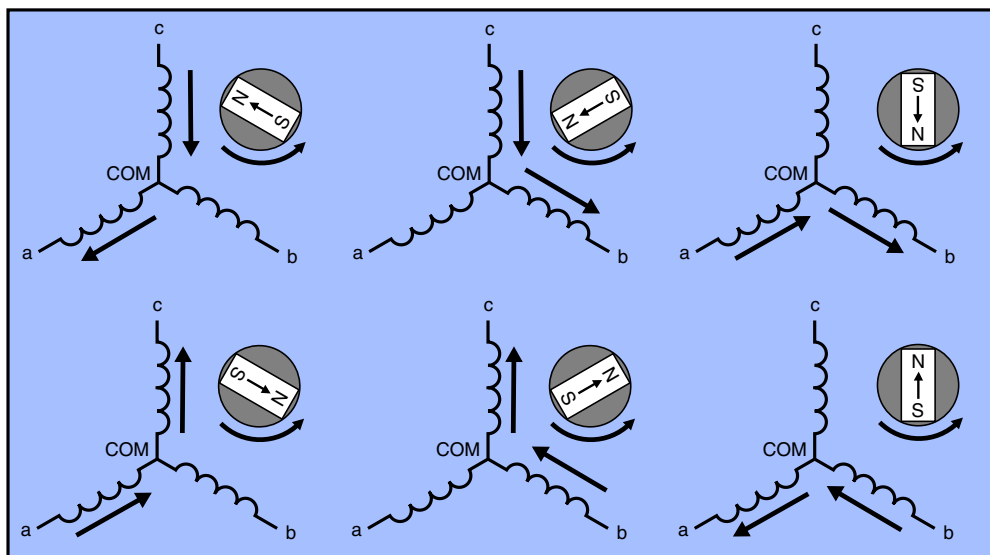

**Figure 3. Six Connections** – By monitoring the Hall sensors, the stator winding fields can be made to rotate so that the resultant field of the two energized stator windings and the pole of the permanent magnet rotor remain at right angles, thereby maximizing the instantaneous torque.

## 1.2 A BRIEF OVERVIEW OF PWM

The first Pulse Width Modulation (PWM) ICs appeared on the market some 40 years ago, so the concept of switching electronics is at least as old. Though the earliest applications were in switching power supplies, it was not much later that the technique was employed in brushless motors.

The principal benefit of PWM as a control technique becomes clear by examining Figure 4. The traditional linear power delivery technique for limiting power simply employs a variable resistance as depicted in Figure 4a. When maximum output is commanded, the driver reduces resistance of the pass element to a minimum. At this output level, losses in the linear circuit are relatively low. When zero output is commanded, the pass element resistance again approaches infinity and losses again approach zero.

The disadvantage of the linear circuit becomes clear in the midrange when the output level is in the vicinity of 50%. At these levels the resistance of the pass element is equal to the load resistance which means the heat generated in the amplifier is equal to the power delivered to the load! In other words, a linear control circuit exhibits a worst case efficiency of 50% when driving resistive loads at midrange power levels. What's more, when the load is reactive, this efficiency drops even further.

Now consider the efficiencies of the switching PWM operation as illustrated in Figure 4b. In a PWM control system, an analog input level is converted into a variable-duty-cycle switch drive signal, as depicted in the figure. The process of switching from one electrical state to another, which in this case is simply between OFF and ON, is called "modulation" – thus the phrase *Pulse Width Modulation* or PWM.

Beginning at zero duty cycle, which is to say OFF all the time, the duty cycle is often advanced as the motor begins to rotate until it is running at the speed and/or the torque required by the application.

In the case of a PWM control circuit, the losses are primarily due to the ON resistance of the switching FET and the flyback diode which is why efficiencies as high as 80% to 95% are routine. However, at high switching frequencies, the energy required to turn the FETs on and off can become significant.

In addition to enhanced efficiency, PWM can provide additional benefits which include limiting the start-up current, controlling speed and controlling torque. The optimum switching frequency will depend on inertia and inductance of the brushless motor chosen, as well as the application.

The choice of switching frequency affects both the losses and the magnitude of the ripple current. A good rule of thumb is that in general, raising the switching frequency increases the PWM losses. On the other hand, lowering the switching frequency limits the bandwidth of the system and can raise the heights of the ripple current pulses to the point they become destructive or shut down the brushless motor driver IC. The ripple current pulses are depicted in Figure 5 and discussed in more detail later.

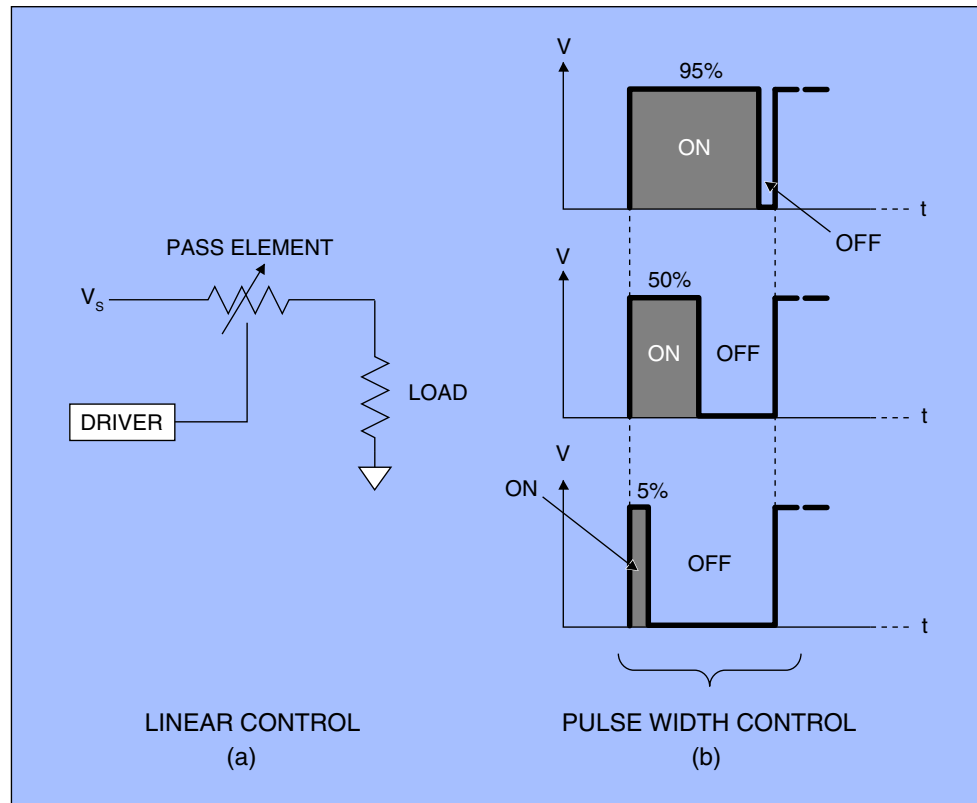

**Figure 4. PWM versus Linear Control** – PWM control in (b) exhibits far lower losses than the traditional linear control technique in (a).

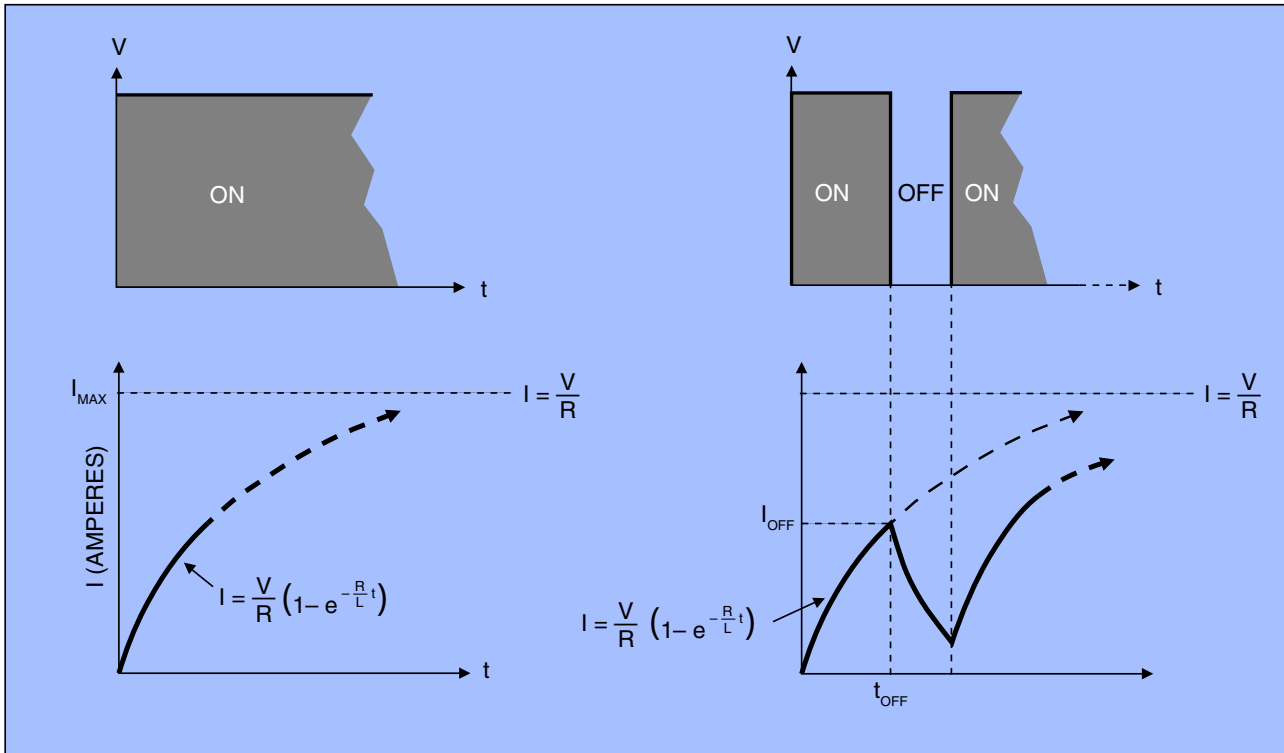

**Figure 5.** a) Current behavior with a steady-state excitation  
b) Current behavior with PWM excitation

### 1.3 INTEGRATED DRIVERS

Until the introduction of off-the-shelf brushless motor drivers, such as the Apex Precision Power SA303 and SA306, the development of three-phase driver circuits had to be configured discretely using three gate drivers and six FETs. Devices like the SA303 and SA306 provide an integrated, fully-protected, three-phase brushless motor IC solution capable of delivering power levels of up to 300 watts<sup>1</sup>. The SA303 and SA306 is fabricated using a multi-technology process that employs CMOS logic control together with DMOS output power devices. This brushless motor driver includes protection features such as overcurrent, short-circuit and over-temperature warning signals.

Operation of the SA303 and SA306 is shown in Figure 2. The SA306 features three independent, DMOS FET half bridges that provide up to 15 amperes PEAK output current under microcontroller or DSP control. As the motor rotor revolves in operation, the controller causes one motor terminal to be driven high, a second low and the third to float, as depicted in Figure 3. Proper synchronization of this sequence is assured by the feedback from the Hall sensors which keeps the microcontroller informed of the position of the rotor with regard to the stator windings at known instants.

“Shoot through” protection is included in this brushless motor driver IC. Shoot through identifies the state in which both the upper and lower portions of two half bridges are on at the same time. This must be avoided, for if it were to occur, it would overload the circuit and destroy the FETs. Consequently, a “dead time” is programmed to allow the FETs to fully commutate to the next state before power is applied to the ON FETs.

Fault status indication and current level monitors are provided directly to the SA303 and SA306 controller. Output currents are measured using an innovative low-loss technique. The SA303 and SA306 also offers superior thermal performance with a flexible footprint.

All brushless motors are driven by microcontrollers or some other intelligent system. A number of manufacturers including Analog Devices, Freescale, Microchip, and Texas Instruments market microcontrollers for motion control – and more specifically for driving brushless motors.

Although there are a number of sources which you can turn to for assistance in choosing a motor, brushless or otherwise, a good starting point is shared in Reference 2. As the author points out, choosing a motor requires looking at a whole list of issues including efficiency, torque, power reliability, and cost. (We also add motor inductance to this check list. As we shall examine shortly, it plays a vital role in how the motor will perform.)

What can be said categorically is that a brushless permanent magnet motor is the highest performing motor in terms of torque versus efficiency. Brushless motors allow you to consider a wide variety of performance options in designing your application. As we have explained prior, with a brushless motor you have control of all three stator windings, which is not the case with a traditional DC motor and its brush commutation. If your decision is to follow the brushless route, some important guidelines are outlined below.

## 2.1 BRUSHLESS MOTOR BEHAVIOR — AN OVERVIEW

One of the most critical operations for a brushless motor — also true for a brush motor — is when power is first applied to the motor while at rest. At that time the rotor is stationary and is delivering no “back EMF” or  $V_{\text{BEMF}}$ .  $V_{\text{BEMF}}$  can be expressed as:

$$V_{\text{BEMF}} = (K_b)(\text{Speed}) \quad (1)$$

Where:

$K_b$  = voltage constant (volts/1000 RPM)

Speed = revolutions per minute (expressed in thousands)

Once a voltage is applied to the motor, the rotor begins turning, generating a  $V_{\text{BEMF}}$  governed by Equation (1).

If we ignore for the moment that we plan to drive the motor with a PWM source and assume the motor is driven by a steady-state voltage, then we can express the current by this equation:

$$I = [(V - V_{\text{BEMF}})/R_m][1 - e^{-Rt/L_m}] \quad (2)$$

Where:

$V$  = the applied voltage

$V_{\text{BEMF}}$  = back EMF

$R_m$  = stator resistance (winding pair)

$L_m$  = stator inductance (winding pair)

Note that in Equation (2) the current ( $I$ ) at any moment is a function of both the back EMF ( $V_{\text{BEMF}}$ ) and the time ( $t$ ). The current when the motor is stopped ( $V_{\text{BEMF}} = 0$ ) is illustrated in Figure 5a and is a familiar waveform for characterizing the current in any L-R circuit with its rise time governed by the time constant  $L/R$ .

Now let's exchange the steady-state excitation voltage for a PWM source, as shown in Figure 5b. The current rises until the first ON pulse ends. When the voltage abruptly falls to zero at the end of the first applied voltage pulse, the current begins to decay towards zero. However, the next pulse will again drive the current upwards, and so forth, so that the current continues to rise. As the motor accelerates, the current waveform will exhibit a sawtooth profile. This sawtooth characteristic is also known as ripple. Because torque is directly proportional to current, the sequence of rising current pulses drives the motor and develops a corresponding torque that accelerates the motor.

The applied voltage, the switching frequency and the PWM duty cycle are three crucial parameters that can be programmed independently. How these variables are selected will effect the behavior of the motor with regard to how fast it will accelerate, and how fast its speed and torque will develop.

## 2.2 A Specific Example

This example begins by choosing a motor that will exhibit the mechanical performance required — which is to say the torque, the efficiency and the other specifications already discussed, are sufficient to meet the motor drive requirements of the end system. For this example a low-inertia, brushless motor will be used that delivers 55 oz-in of torque at 5000 rpm. The selected motor is a Galil Motion Control BLM-N23-50-1000-B ([www.galilmc.com](http://www.galilmc.com)). The winding characteristics of this motor include a stator-winding pair that exhibits a resistance ( $R_m$ ) of 1.2 ohms and an inductance ( $L_m$ ) of 2.6 millihenries. The torque constant ( $K_t$ ) of the motor is 12.1 oz-in/A and the voltage constant  $K_b$  of the motor is 8.9 volts/1000 RPM.

First make certain that the maximum current capability of the IC driver — in this case the SA306 with an output of 15 amperes — is not reached.

If  $V/R \leq 15$  amperes, then regardless of the other parameters, the current can never reach this value. This can be seen in figures 5a and 5b where both the first and all succeeding pulses approach the value of  $V/R$ . Another way of looking at it is the current in any L-R circuit can never exceed  $V/R$ .

If  $V/R > 15$  amperes, then consideration must be given to several factors in the design. In this example, the  $R_m$  is 1.2 ohms. Assuming a 60 volt drive voltage, then  $V/R = 60/1.2 = 50$  amperes. When the initial voltage is applied to the motor, the current ramps up as explained in equation (2). As the back EMF builds up, the current will taper off as shown in Figure 6. Maximum current may never be reached in normal operation because of the back EMF. The torque constant of the motor and the inertial load will govern the rate at which the motor comes up to speed. If the

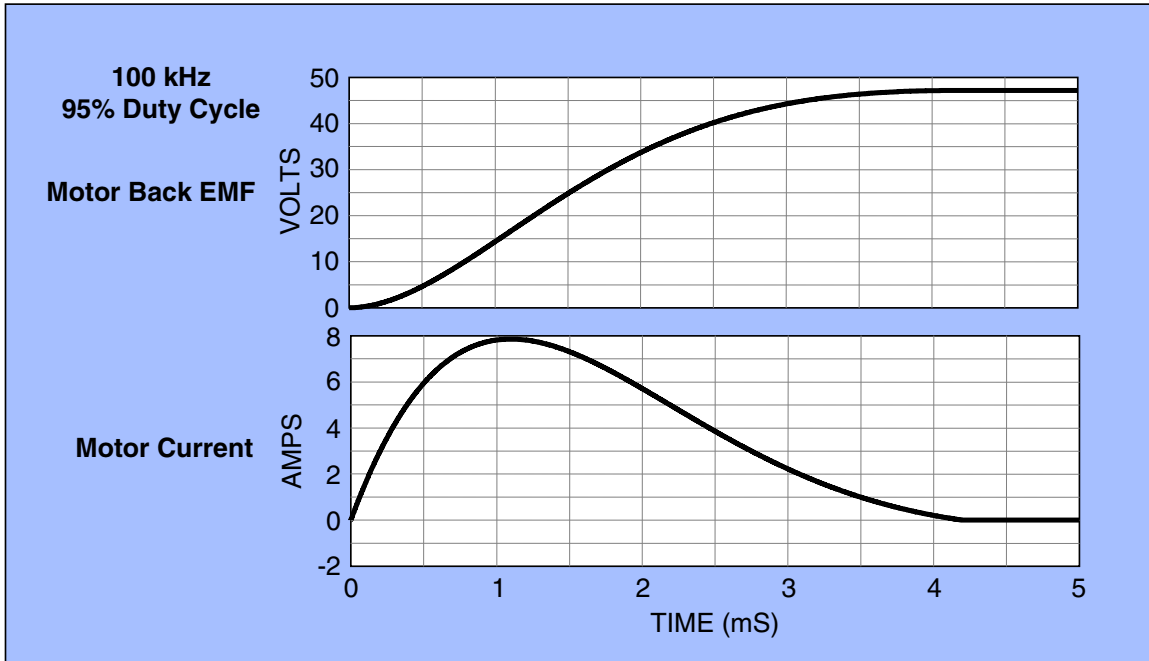

**Figure 6.** A graphical approach to determining maximum motor current – here the dynamic simulation of the Galil BLM-N23-50-1000-B brushless motor is illustrated.

motor has a particularly low L/R time constant relative to the mechanical time constant, the current can reach the maximum well before the motor builds any back EMF.

Note that in this example the simulation depicted in Figure 6 discloses that the current will never rise above 8 amperes — well below the 15 amperes limit. If the current were to exceed the limit of the driver, adding external series resistance or inductance would limit the peak current and di/dt respectively, but each will adversely effect the performance of the system. If the start-up current is controlled with a PWM drive by limiting the duty cycle of each pulse and not to exceed the maximum peak current rating of the driver, the motor can safely accelerate. The current monitor feature of the SA303 and SA306 makes this type of feedback relatively simple to implement.

By employing a microcontroller and monitoring the instantaneous currents in all three phases, a closed-loop algorithm can be developed for start-up purposes which would hold the peak current near 15 amperes without actually exceeding it. A small amount of headroom makes good sense so programming for a 12 ampere motor current would be best. The advantage of this approach is that it optimizes the run up and keeps the current and the acceleration as high as possible. In this approach the duty cycle would be modulated, based upon the current sensed in the three phases, as depicted in Figure 2. Further discussion on the use of microcontrollers to drive brushless motors is available in References 3, 4, and 5.

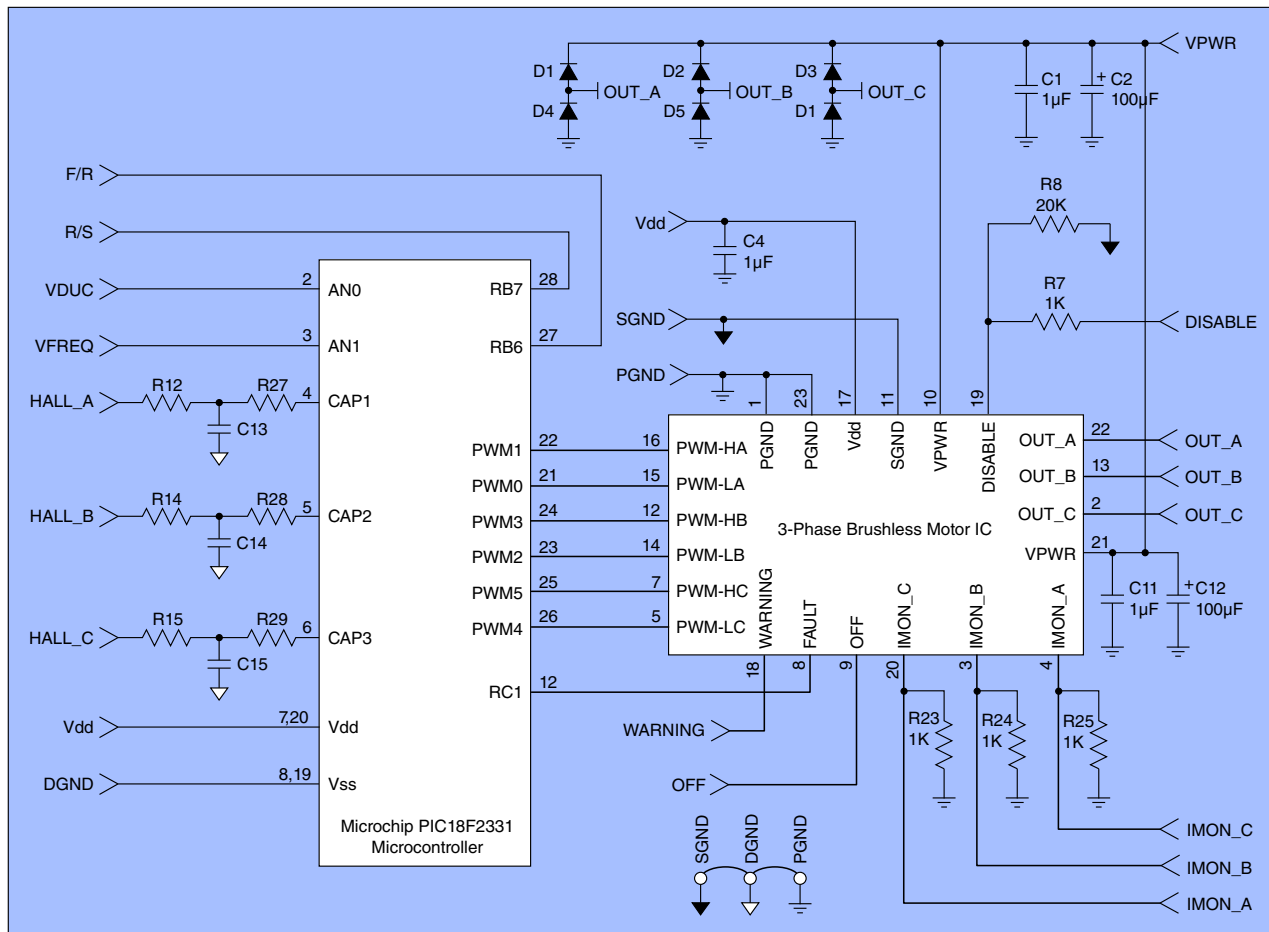

Figure 7. A specific example – Combining the brushless motor IC with a Microchip PIC18F2331 microcontroller

### 3. Appendix

Proportional integral derivative controller – A Proportional-integral-derivative controller (PID controller) is a feedback loop technique employed in control systems. It can be thought of as an extreme form of a phase lead-lag compensator. A PID controller has one pole at the origin and the other at infinity<sup>9</sup>. It is used to compare a measured value with a reference value. As employed in motor control the values may be either speed or torque. The difference value is then employed to calculate a new value to restore the value – be it speed or torque to the setpoint value. A PID loop produces accurate, stable control in cases, whereas a simple proportional control would be likely to induce a steady-state error or would induce oscillation. Unlike more complicated control algorithms based on optimal control theory, PID controllers do not require advanced mathematics to develop a design.

A standard PID controller is also known as a "three-term" controller and can be expressed in the "parallel form" by Equation (4) or the "ideal form" by Equation (5):

$$G(s) = K_p + K_i \frac{1}{s} + K_d s \quad (4)$$

$$= K_p \left( 1 + \frac{1}{T_i s} + T_d s \right) \quad (5)$$

Where:

- $K_p$  is the proportional gain
- $K_i$  the integral gain
- $K_d$  the derivative gain
- $T_i$  the integral time constant
- $T_d$  the derivative time constant.

- The proportional term provides an overall control response that is proportional to the error signal through the all-pass gain factor.
  - The integral term reduces steady-state errors through low-frequency compensation by an integrator.
  - The derivative term improves the transient response through high-frequency compensation by a differentiator.
- The effects of each of these three terms on closed-loop performance are summarized in Table 1.

| <b>Closed-Loop Response</b> | <b>Rise Time</b> | <b>Overshoot</b> | <b>Settling Time</b> | <b>Steady-State Error</b> | <b>Stability</b> |
|-----------------------------|------------------|------------------|----------------------|---------------------------|------------------|
| Increasing $K_p$            | Decrease         | Increase         | Small Increase       | Decrease                  | Degrade          |
| Increasing $K_i$            | Small Decrease   | Increase         | Increase             | Large Decrease            | Degrade          |
| Increasing $K_d$            | Small Decrease   | Decrease         | Decrease             | Minor Change              | Improve          |

**4. References**

1. SA306 or SA303 Pulse Width Modulation Amplifier Data Sheet, www.Cirrus.com
2. Motion Control Primer by David Palombo, www.aveox.com
3. Brushless DC Motor Fundamentals, AN885, www.microchip.com
4. Brushless DC Motor Control Using PIC18FXX31 MCUs, AN899, www.microchip.com
5. Sensored BLDC Motor Control Using dsPIC30F2010, AN957, www.microchip.com
6. DB64R Demonstration Board For SA306/SA303, www.Cirrus.com
7. Application Note 22, SOA (Safe Operating Area) and Load Lines, www.Cirrus.com
8. Application Note 11, Thermal Techniques, www.Cirrus.com
9. PID Control System Analysis, Design, and Technology, by Kiam Heong Ang, Gregory Chong and Yun Li, IEEE Transactions on Control Systems Technology, Vol. 13, No. 4, July 2005, pages 559 - 576

**5. Bibliography**

- "Modeling, Simulation, and Analysis of Permanent-Magnet Motor Drives, Part II: The Brushless DC Motor Drive" by Pragasen and Ramu Krishnan, IEEE Transactions on Industry Applications, Vol. 25, No. 2, March/April 1989, pages 274-279
- "A New Simulation Model of BLDC Motor with Real Back EMF Waveform" by Y.S. Jeon, H.S. Mok, G.H. Choe, D.K. Kim, J.S. Ryu, 7th Workshop on Computers in Power Electronics, 2000; pages 217-220

**CONTACTING CIRRUS LOGIC SUPPORT**

For all Apex Precision Power product questions and inquiries, call toll free 800-546-2739 in North America. For inquiries via email, please contact [tucson.support@cirrus.com](mailto:tucson.support@cirrus.com). International customers can also request support by contacting their local Cirrus Logic Sales Representative. To find the one nearest to you, go to [www.cirrus.com](http://www.cirrus.com)

**IMPORTANT NOTICE**

Cirrus Logic, Inc. and its subsidiaries ("Cirrus") believe that the information contained in this document is accurate and reliable. However, the information is subject to change without notice and is provided "AS IS" without warranty of any kind (express or implied). Customers are advised to obtain the latest version of relevant information to verify, before placing orders, that information being relied on is current and complete. All products are sold subject to the terms and conditions of sale supplied at the time of order acknowledgment, including those pertaining to warranty, indemnification, and limitation of liability. No responsibility is assumed by Cirrus for the use of this information, including use of this information as the basis for manufacture or sale of any items, or for infringement of patents or other rights of third parties. This document is the property of Cirrus and by furnishing this information, Cirrus grants no license, express or implied under any patents, mask work rights, copyrights, trademarks, trade secrets or other intellectual property rights. Cirrus owns the copyrights associated with the information contained herein and gives consent for copies to be made of the information only for use within your organization with respect to Cirrus integrated circuits or other products of Cirrus. This consent does not extend to other copying such as copying for general distribution, advertising or promotional purposes, or for creating any work for resale.

CERTAIN APPLICATIONS USING SEMICONDUCTOR PRODUCTS MAY INVOLVE POTENTIAL RISKS OF DEATH, PERSONAL INJURY, OR SEVERE PROPERTY OR ENVIRONMENTAL DAMAGE ("CRITICAL APPLICATIONS"). CIRRUS PRODUCTS ARE NOT DESIGNED, AUTHORIZED OR WARRANTED TO BE SUITABLE FOR USE IN PRODUCTS SURGICALLY IMPLANTED INTO THE BODY, AUTOMOTIVE SAFETY OR SECURITY DEVICES, LIFE SUPPORT PRODUCTS OR OTHER CRITICAL APPLICATIONS. INCLUSION OF CIRRUS PRODUCTS IN SUCH APPLICATIONS IS UNDERSTOOD TO BE FULLY AT THE CUSTOMER'S RISK AND CIRRUS DISCLAIMS AND MAKES NO WARRANTY, EXPRESS, STATUTORY OR IMPLIED, INCLUDING THE IMPLIED WARRANTIES OF MERCHANTABILITY AND FITNESS FOR PARTICULAR PURPOSE, WITH REGARD TO ANY CIRRUS PRODUCT THAT IS USED IN SUCH A MANNER. IF THE CUSTOMER OR CUSTOMER'S CUSTOMER USES OR PERMITS THE USE OF CIRRUS PRODUCTS IN CRITICAL APPLICATIONS, CUSTOMER AGREES, BY SUCH USE, TO FULLY INDEMNIFY CIRRUS, ITS OFFICERS, DIRECTORS, EMPLOYEES, DISTRIBUTORS AND OTHER AGENTS FROM ANY AND ALL LIABILITY, INCLUDING ATTORNEYS' FEES AND COSTS, THAT MAY RESULT FROM OR ARISE IN CONNECTION WITH THESE USES.

Cirrus Logic, Cirrus, and the Cirrus Logic logo designs, Apex Precision Power, Apex and the Apex Precision Power logo designs are trademarks of Cirrus Logic, Inc. All other brand and product names in this document may be trademarks or service marks of their respective owners.