

Analog/Digital Evaluation CCD Cameras

Features

- CCD Camera Processor Board
- Includes CS7615 Analog Processor
- Includes CS7666 Digital Processor
- Includes CS4954 TV Encoder
- 4:2:2 Component Digital Video
- ITU-R BT.656 Compliant Transport
- NTSC/PAL Composite Video Output
- S-Video Output
- I²C Control Interface
- Programmable Image Adjustment
- 12 mm and C-Mount Lens Options

Description

The CRD7666-7C is a CCD camera that provides a simple to use evaluation and demonstration platform using the CS7615 which performs CDS and analog-to-digital conversion of the CCD signal and the CS7666 which converts the digitized CCD output data into the international standard 4:2:2 digital video conforming to H.656 transport protocol. Also included is a CS4954 video encoder that converts 4:2:2 digital video to analog NTSC/PAL video and S-Video.

The board set produces simultaneous digital AND analog video outputs. Analog output requires a standard video monitor. Control software is included to adjust camera settings and operational features.

In order to view the digital video, a cable and a PCI card are provided as well as viewing software on CD-ROM.

The camera consists of two boards (1) CCD+Video processing board and (2) video encoder board.

All cameras include external power module, parallel port I²C controller and control software to adjust camera settings and operational features. Digital output is provided via a 26-pin connector and the NTSC/PAL output is via standard RCA and S-Video connectors.

ORDERING INFORMATION

CRD7666-7C

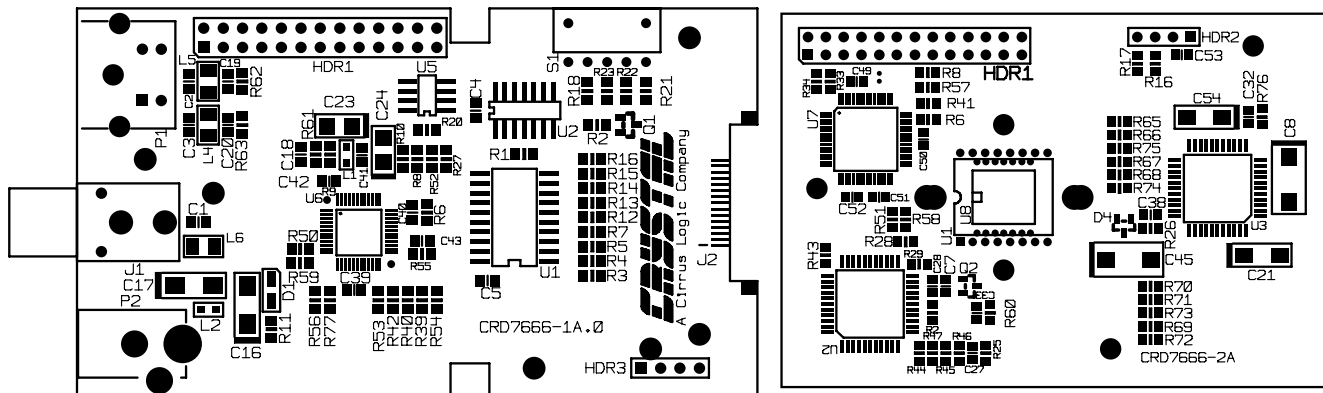

Preliminary Product Information

This document contains information for a new product. Cirrus Logic reserves the right to modify this product without notice.

OPERATION

The CCD+Video processing board includes the CS7615 Analog Video Signal Processor which performs analog processing and converts the analog CCD output to a digital format. Also included on the processor board is the CS7666 Digital Video Color-Space Processor, which decodes the MYCG (magenta, yellow, cyan, and green) CCD imager data and converts it to the industry standard 4:2:2 component digital video in YCrCb format. The component digital video can be used directly or after processing by the video encoder, the composite output formats can be used. The camera uses a +5 V supply in the form of a wall plug-in unit.

Power Requirements

The camera requires a reasonably filtered (less than 200 mV ripple) +5 V power supply feed, which is used by the processor board and the encoder board. A charge pump is used to generate both +15 V and -8 V required by the CCD imager.

Analog Processor

The CCD output is connected to the CS7615 analog processor chip (see Figure 4). The CS7615 performs all necessary analog processing, including Correlated-Double-Sampler (CDS), Automatic-Gain-Control (AGC), Black level adjust, and appropriate output data formatting to allow the mosaic (MYCG) CCD imager data to be processed by the CS7666 digital processor. The CS7615 control registers are accessible via the I²C control bus.

Digital Processor

The CS7666 digital processor is included on the CCD+Video processor (see Figure 6). The CS7666 converts the digital mosaic data from the CS7615, into 4:2:2 component digital video that adheres to the ITU H.656 transport protocol. The Automatic-White-Balance and other control registers are accessible via the main I²C interface.

I²C Control and Settings

The camera incorporates an I²C EEPROM, which provides all necessary register settings for the camera on power-up. This EEPROM can be programmed using either the digital video connector HDR1 (Figure 7), HDR4 (Figure 6) or the I²C external connector HDR2 (Figure 1). Only one of these approaches should be used at a time. The camera must be re-powered, or the CS7666 must be reset, for these new EEPROM settings to take effect. Additionally, all registers are accessible using the I²C control channel, and the Crystal software is compatible with both connection schemes.

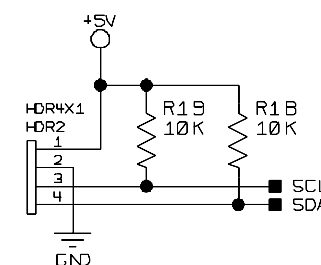

Figure 1. External I²C Connector.

Multiple Configurations

Switch S1 is used to select between several preprogrammed configurations. The CRD7666-7C is preconfigured for 720x480 NTSC (S1 = 100x). the Pal version, CRD7666-7CP, is preconfigured for 720x576 (S1 = 010x). When shipped as part of the CRD7615-8P PCI kit, S1 = 000x and the camera provides 640x480 digital video only.

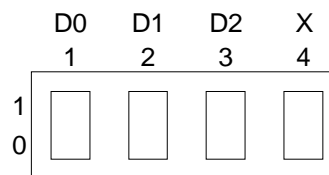

Figure 2. S1

Digital Output Options

The camera has a 15-pin PCMCIA style connector which connects via a cable to a PCI card (Figure 7) and provides a simple means of integrating the camera's digital output into a PC.

Composite Output Options

The CRD7615-7A and -7C provide two analog output mode connectors for composite and S-Video. The Composite output is available in connector J1, while the S-Video is available in connector P1 (Figure 9).

Schematics and Gerber Files

The CRD7666-7C schematics and PCB layout files are available upon request in Zuken-Radac file format. The PCB Gerber files are also available upon request.

SPECIAL NOTES

- 1) The camera power supply can be configured to receive power from an external power module or from the digital video connector.

CCD+VIDEO PROCESSOR BOARD

The CCD imager and Video processor board of the camera includes a Panasonic MN3711OFP CCD imager and a Panasonic MN3113F vertical driver (with integrated charge pump). (Figure 5). Additionally, the CS7615 Analog Processor (Figure 4) is also included. The CS7666 Digital Video Processor carries out all color space processing as well as standard image processing (see CS7666 data sheet for further details). A connector (Figure 3) between

the video processor board and the associated encoder board carries all necessary signals. The supported camera mounts are available from Marshall and can be used for both simple 12mm×0.5 lenses as well as standard C-Mount lenses.

VIDEO ENCODER BOARD

The main digital output connector (Figure 7) provides industry standard H.656 compliant component digital video output from the CCD board to the video encoder board. The video encoder (Figure 9) provides both composite and S-Video output via connectors J1 and P1. The board-to-board connector (Figure 6) routes all necessary signals to the upper half of the camera.

Schematic & Layout Review Service

Confirm Optimum
Schematic & Layout
Before Building Your Board.

For Our Free Review Service
Call Applications Engineering.



Call : (5 1 2) 4 4 5 - 7 2 2 2

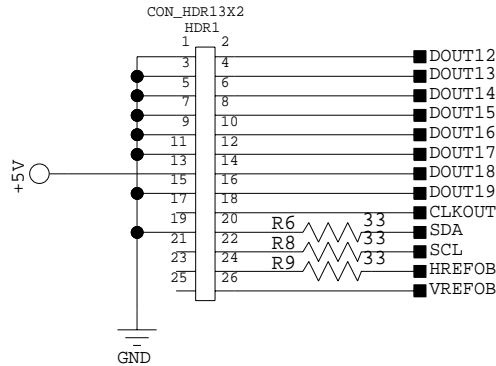

Figure 3. Analog Board to Digital Board Connector.

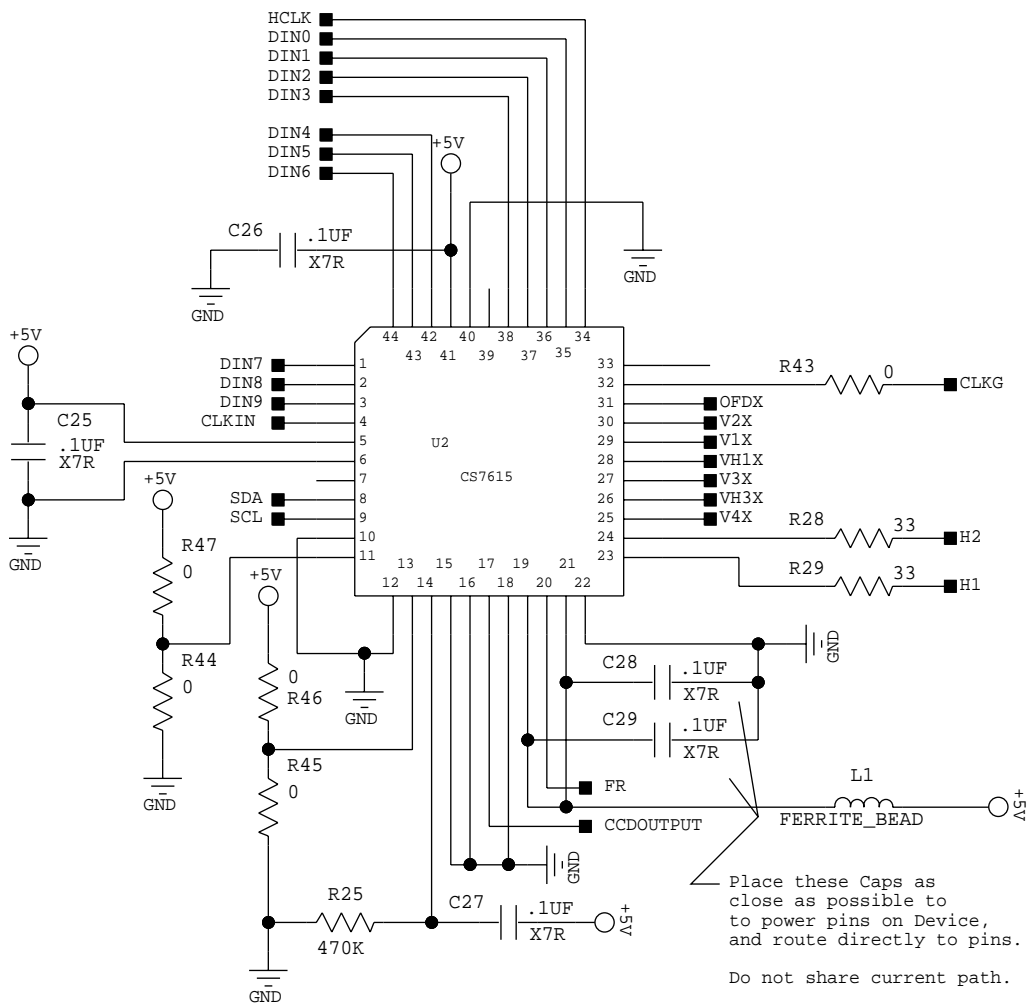

Figure 4. CS7615 Analog Processor Schematic.

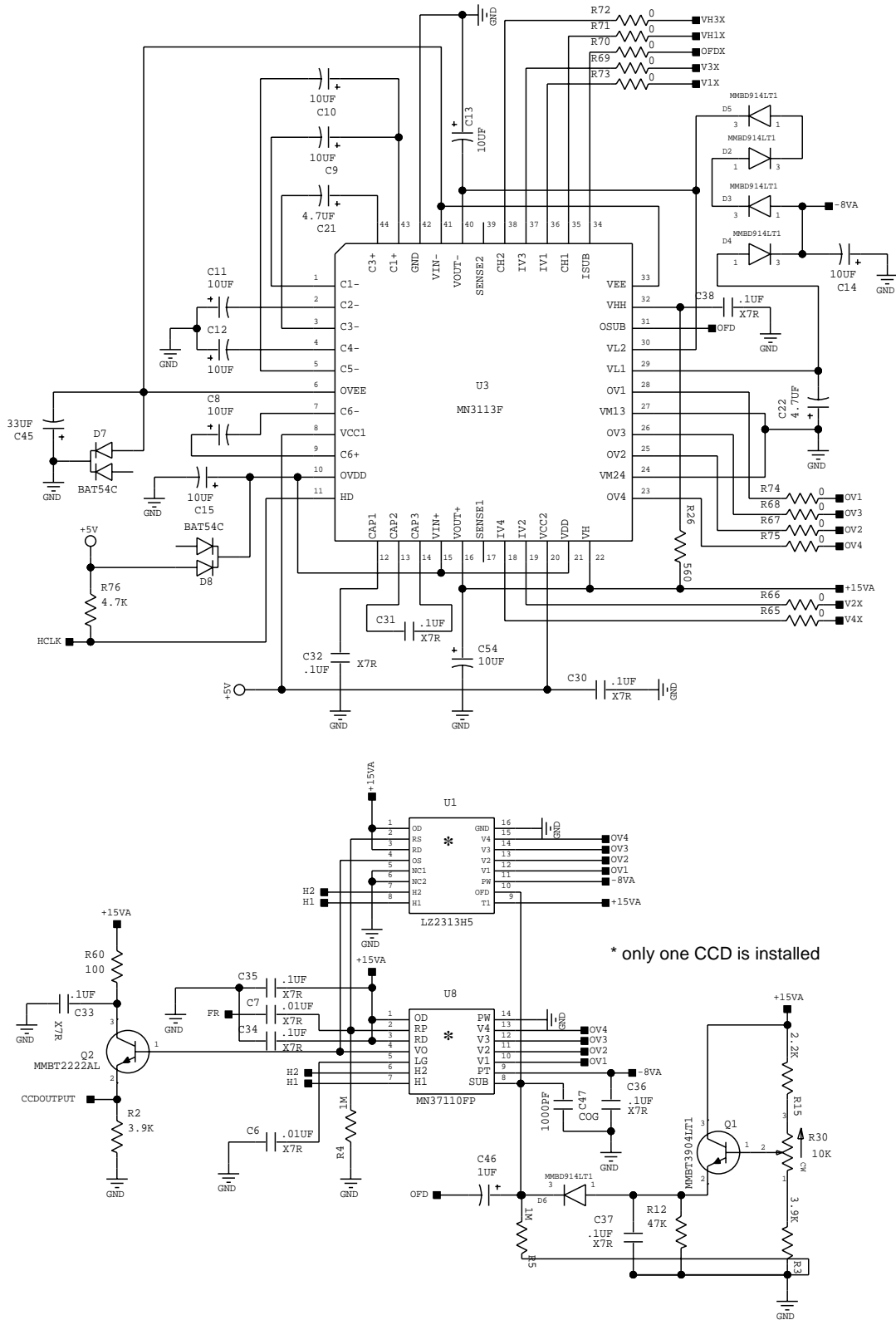

Figure 5. CCD Imager, Vertical Driver, and Charge Pump Circuit.

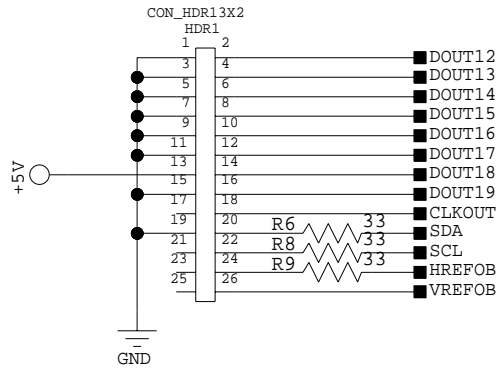

Figure 6. Digital Board to Analog Board Connector.

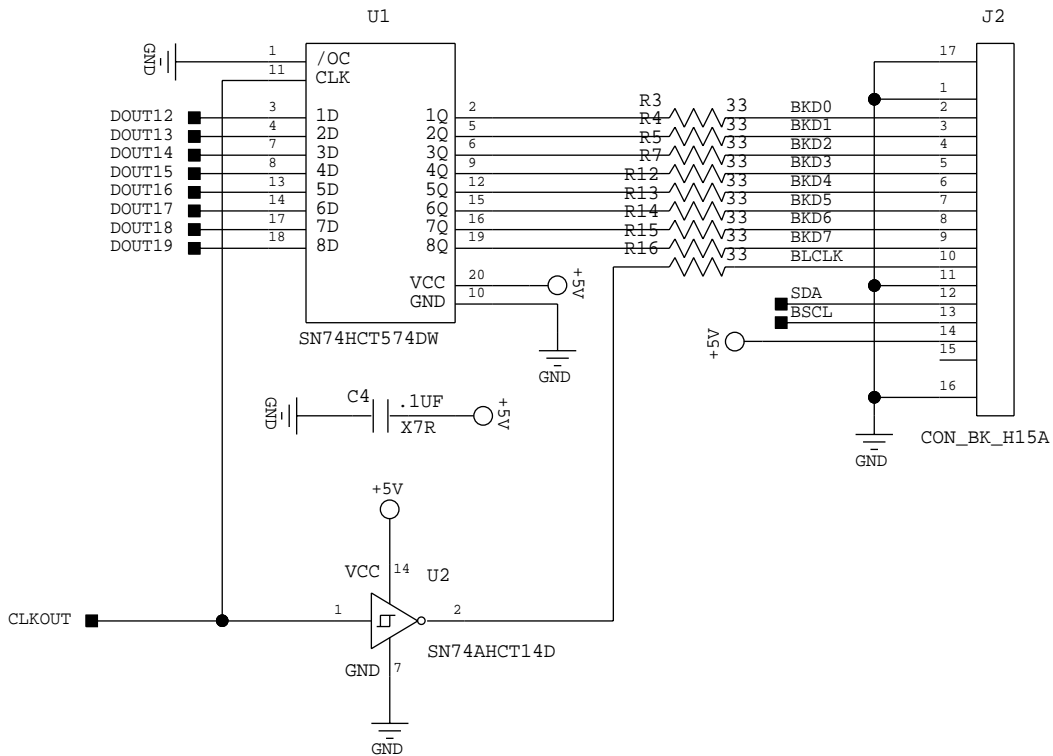

Figure 7. Main H.656 Component Digital Video Output.

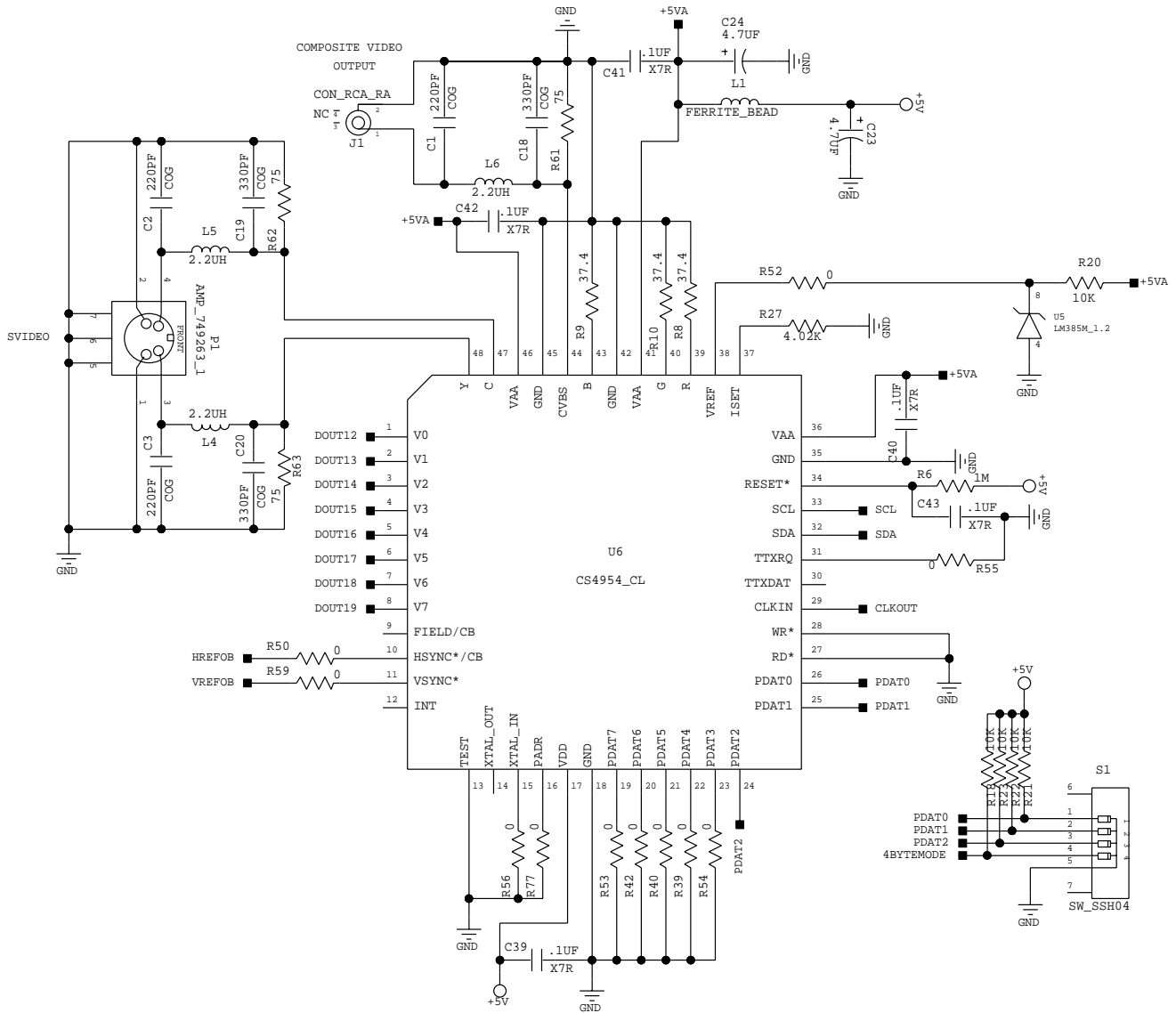
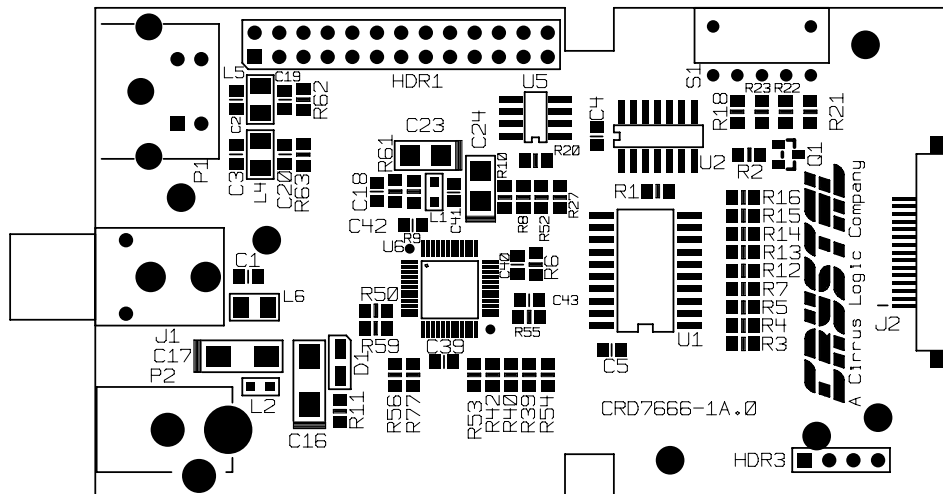

Figure 9. Video Encoder Details.

CRYSTAL SEMICONDUCTOR
Camera CCD
CRD7666-1 Rev A



SILKSCREEN - TOP

Figure 10. Silkscreen Top

CRYSTAL SEMICONDUCTOR
Camera CCD
CRD7666-2 Rev A Mod 0

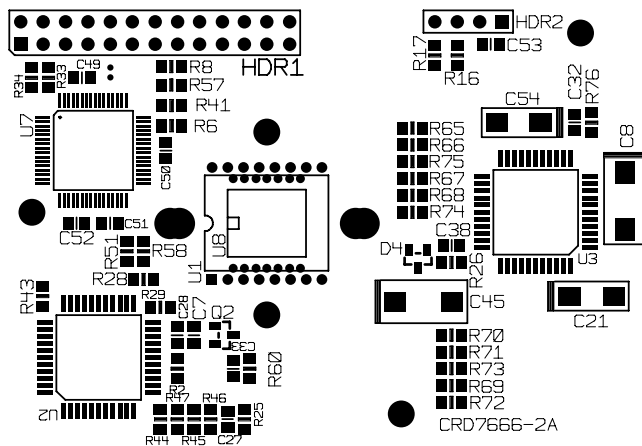

SILKSCREEN - TOP

Figure 11. Silkscreen Top.

CRYSTAL SEMICONDUCTOR
Camera CCD
CRD7666-2 Rev A Mod 0

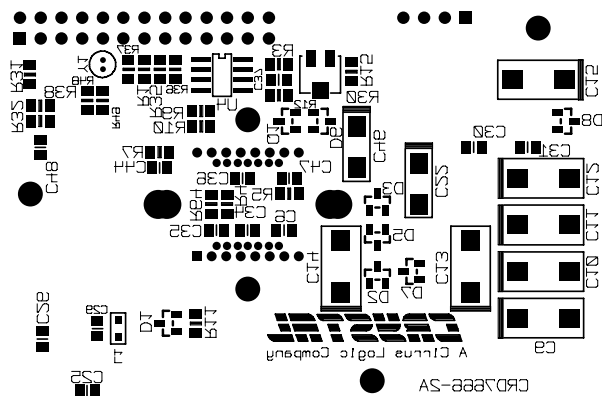

SILKSCREEN - BOTTOM

Figure 12. Silkscreen Bottom

BILL OF MATERIALS

CRD7666-7C : 1					
ITEM	QTY	REF	MFG. PART NUMBER	MFG.	DESCRIPTION
1	3	C1-3	C0805C221J5G5CA	KEMET	CAP, 220PF,COG, S0805, 50 VOLT, 5%
2	7	C4-5,C39-43	C0805C104J1RCA	KEMET	CAP, .1UF, X7R, S0805, 25 VOLT, 5%
3	2	C16-17	TAJ_C_106_K_016	AVX	CAP, TANT, 10UF, S6032,16 VOLT, 10%
4	3	C18-20	C0805C331J5GAC	KEMET	CAP, 330PF, COG, S0805, 50 VOLT, 5%
5	2	C23-24	T491B475K016AS	KEMET	CAP, TANT, 4.7UF, S3528, 16 VOLT, 10%
6	1	D1	LN1351C	PANASONIC	LED, GREEN, SMT
7	1	HDR1	CLH-113-F-D-TE	SAMTEC	HEADER, 13 X 2, .1" CENTER
8	1	HDR3	640455-4	AMP	HEADER, 4 X 1, .1" CENTER, RIGHT ANGLE
9	1	J1	ARJ-2018-1	AD ELECTRONIC	CONNECTOR, RCA, RIGHT ANGLE, GOLD
10	1	J2	BK-H15A-1213-91	JST	CONNECTOR
11	2	L1-2	BLM21A601SPT	MURATA	INDUCTOR, FERRITE BEAD, S0805, 600
12	3	L4-6	ELJ_NA2R2JF	PANASONIC	INDUCTOR, FERRITE BEAD, S1210, 2.2UH
13	1	P1	749263_1	AMP	CONNECTOR
14	1	P2	PJ-002A	CUI STACK	CONNECTOR, POWER, RAPC722
15	1	Q1	MMBT2222AL	MOTOROLA	MMBT2222AL, SOT-23
16	7	R1-2,R18,R20-23	RES0805	MANY	RES, 10K, S0805, 1%
17	9	R3-5,R7,R12-16	RES0805	MANY	RES, 33-OHM, S0805, 5%
18	1	R6	RES0805	MANY	RES, 1-MEG, S0805, 1%
19	3	R8-10	RES0805	MANY	RES, 37.4-OHM, S0805, 1%
20	1	R11	RES0805	MANY	RES, 1K, S0805, 1%
21	1	R27	RES0805	MANY	RES, 4.02K, S0805, 1%
22	11	R39-40,R42,R50,R52-56,R59,R77	RES0805	MANY	RES, 0-OHM, S0805, 1%
23	3	R61-63	RES0805	MANY	RES, 75-OHM, S0805, 1%
24	1	S1	SSH04	AUGAT INC.	SWITCH, RA, LOW PROFILE
25	1	U1	SN74HCT574DW	TEXAS INSTRU	SN74HCT574DW, SOIC-20W
26	1	U2	SN74AHCT14D	TEXAS INSTRU	SN74AHCT14D, SO14
27	1	U5	LM385M_1P2	NATIONAL_SEMI	LM385M_1P2, SO8
28	1	U6	CS4954_CL	CRYSTAL SEMI.	CS4954_CL, QFP48



CRD7666-7C : 2

ITEM	QTY	REF	MFG. PART NUMBER	MFG.	DESCRIPTION	NOTES
1	2	C6-7	C0805C103J5RAC	KEMET	CAP, .01UF, X7R, S0805, 25 VOLT, 5%	
2	8	C8-15	T491D106K035AS	KEMET	CAP, TANT, 10UF, S7343, 35 VOLT, 10%	
3	2	C21-22	T491C475K025AS	KEMET	CAP, TANT, 4.7UF, S6032, 25 VOLT, 10%	
4	15	C25-38,C44,C48-53	C0805C104J5RAC	KEMET	CAP, .1UF, X7R, S0805, 25 VOLT, 5%	
5	1	C45	T491D336K020AS	KEMET	CAP, TANT, 33UF, S7343, 20 VOLT, 10%	
6	1	C46	T491C105K050AS	KEMET	CAP, TANT, 1UF, S6032, 50 VOLT, 10%	
7	1	C47	C0805C102J5GAC	KEMET	CAP, 1000PF, COG, S0805, 50 VOLT, 5%	
8	1	C54	T491C106K020AS	KEMET	CAP, TANT, 10UF, S6032, 20 VOLT, 10%	
9	6	D1-6	MMBD914LT1	MOTOROLA	MMBD914LT1	
10	2	D7-8	BAT54C	ZETEX	BAT54C, SOT-23	
11	1	HDR1	MTSW-113-06-T-D-085	SAMTEC	HEADER, 13 X 2, .1"CENTER	DO NOT POPULATE
12	1	HDR2	640455-4	AMP	HEADER, 4 X 2, .1"CENTER.	
13	1	L1	BLM21A10	MURATA	IND_FB0805_600	
14	1	Q1	MMBT3904LT1	MOTOROLA	MMBT3904LT1, SOT-23	
15	1	Q2	MMBT2222AL	MOTOROLA	MMBT2222AL, SOT-23	
16	1	R1	RES0805	MANY	RES, 6.04K, S0805, 1%, 1/8W	
17	2	R2-3	RES0805	MANY	RES, 3.9K, S0805, 5%, 1/8W	
18	3	R4-5,R7	RES0805	MANY	RES, 1M, S0805, 1%, 1/8W	
19	6	R6,R8-10,R28-29	RES0805	MANY	RES, 33-OHM, S0805, 5%, 1/8W	
20	1	R11	RES0805	MANY	RES, 100K, S0805, 1%, 1/8W	
21	1	R12	RES0805	MANY	RES, 47K, S0805, 5%, 1/8W	
22	1	R15	RES0805	MANY	RES, 2.2K, S0805, 5%, 1/8W	
23	2	R16-17	RES0805	MANY	RES, 10k, S0805, 1%, 1/8W	
24	1	R25	RES0805	MANY	RES, 470K, S0805, 5%, 1/8W	
25	1	R26	RES0805	MANY	RES, 560-OHM, S0805, 5%, 1/8W	
26	1	R30	ST4A103	MEPCOPAL	POT_MEPC_ST4A103, 10K	
27	30	R31-38,R41,R43-R49, R51,R57-58, R65-75	RES0805	MANY	RES, 0-OHM, S0805, 5%, 1/8W	
28	1	R60	RES0805	MANY	RES, 100-OHM, S0805, 1%, 1/8W	
29	1	R64	RES0805	MANY	RES, 15K, S0805, 1%, 1/8W	
30	1	R76	RES0805	MANY	RES, 4.7K, S0805, 5%, 1/8W	
31	1	U1	LZ2313H5	SHARP	LZ2313H5	DO NOT POPULATE
32	1	U2	CS7615	CRYSTAL SEMI	QFP44_10X10	
33	1	U3	MN3113F	PANASONIC		
34	1	U4	X24C04_SO8	XICOR	X24C04_SO8	

CRD7666-7C : 2

ITEM	QTY	REF	MFG. PART NUMBER	MFG.	DESCRIPTION	NOTES
35	1	U7	CS7666	CRYSTAL SEMI.	CS7666_QFP64	
36	1	U8	MN37112FP	PANASONIC	MN37112FP	
37	1	Y1	CA-301 27.000M-C	EPSON	XTL_CA301_27P000M	DO NOT POPULATE
38	1		V-LH3A	MARSHALL	Lens Mount	DO NOT POPULATE
39	1		V-FBG-28	MARSHALL	B/G IR Filter	DO NOT POPULATE
40	1		V-GS	MARSHALL	Gasket to hold Filter	DO NOT POPULATE
41	1		V-4303-6.1	MARSHALL	Lens	DO NOT POPULATE

SMART
Analog™