

## LINEAR OPERATION BASICS

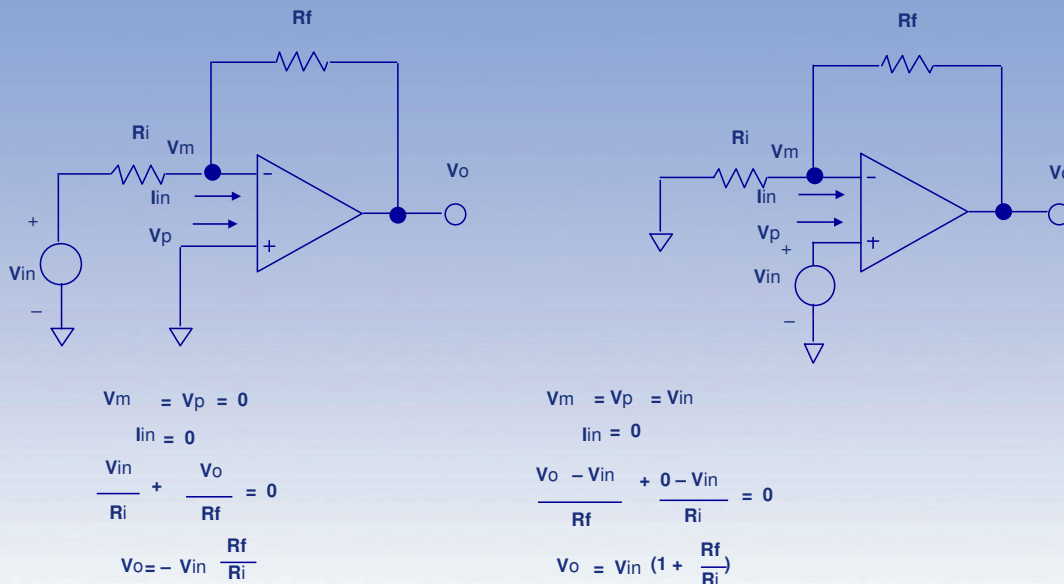

Before we discuss non-linear operation, we will cover some of the basics of linear operation for that mythical creature, the "ideal op amp". The three most important characteristics of an ideal op amp are:

1. Infinite input impedance
2. Zero output impedance
3. Infinite open loop gain

Let's review the inverting configuration in light of these three basic characteristics. #1 dictates that the input current into the op amp is 0. #3 implies that any voltage appearing between the input terminals will result in infinite output voltage. The resistive divider action of  $R_f$  and  $R_i$  causes a portion of the output voltage to be fed back to the inverting input. It is this **NEGATIVE FEEDBACK** action coupled with #3, open loop gain, that keeps the voltage between the two inputs at zero.

In the inverting configuration, this results in a "virtual ground" node. The concept of a virtual ground, coupled with the zero input current flow, allows the "closed loop gain" or transfer function of the circuit to be easily calculated. Current flow in  $R_i$  is equal to  $V_{in}/R_i$ . The same current is forced to flow through  $R_f$ , giving an output voltage of  $-i_{in}R_f$ .

In the non-inverting amplifier, the infinite open loop gain of the amplifier, coupled with negative feedback, force the inverting terminal to be equal to the non-inverting terminal. This sets up a voltage across  $R_i$  which develops a current that also flows through  $R_f$ . Therefore, the total output voltage is  $s V_{in}/R_{in}$  current times the series combination of  $R_f$  and  $R_i$ .

## Class C Output Stages

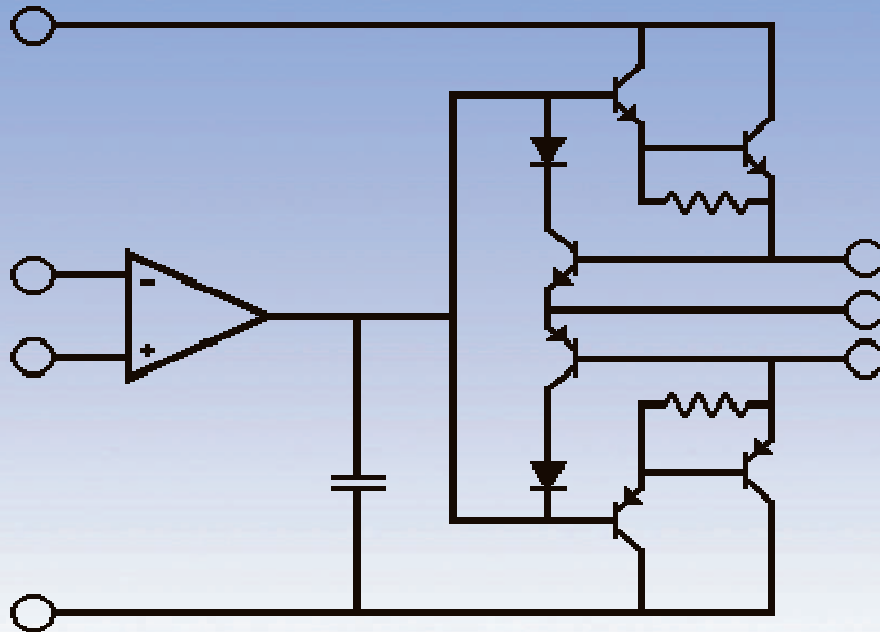

Class “C” output stages tie the bases or gates of the power devices together. Omitting the usual bias network between these bases reduces cost with the penalty of increased crossover distortion.

Assuming a resistive load and the drive stage voltage in the range of  $\pm 0.6V$ . There is no output current because the power devices need about a  $V_{be}$  to turn on. There is a dead band of about  $1.2V$  which the driver must cross over before output current can change polarity. For MOSFET outputs this dead band is usually somewhere between 4 to 6V.

The good news is that because the output does not move, there is no feedback to the driver. It is running open loop during dead band transition and slews across as fast as it can. This means at low frequencies this distortion is quite low. Class “C” outputs are generally not recommended above 1KHz but this varies with tolerance of distortion.

## Op Amp With Class C Output Stage

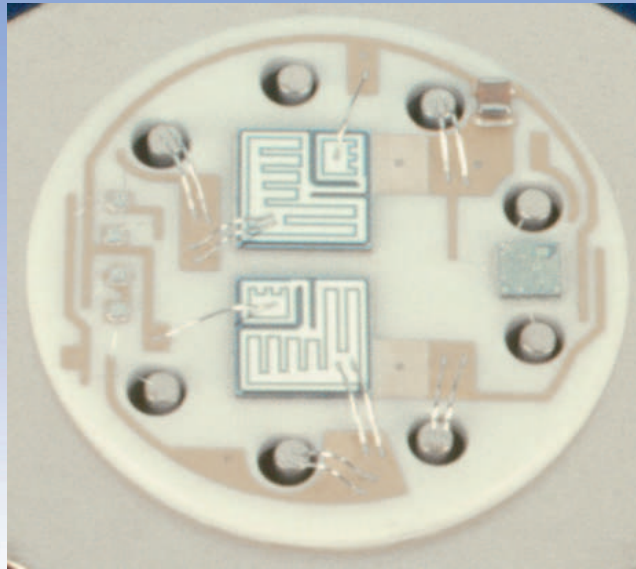

With a minimum transistor count and no resistors, the class “C” amplifiers enjoy a roomy layout. The power transistors are soldered to silver thick film conductors. Small signal devices are epoxied and wire bonded to gold thick film conductors. Wire bonds are 1 mil and 5 mil diameter. The white ceramic substrate is beryllium oxide (BeO) which spreads the heat over a wide area before it travels through the steel header. The substrate is also solder attached.

# Simple Class AB Outputs

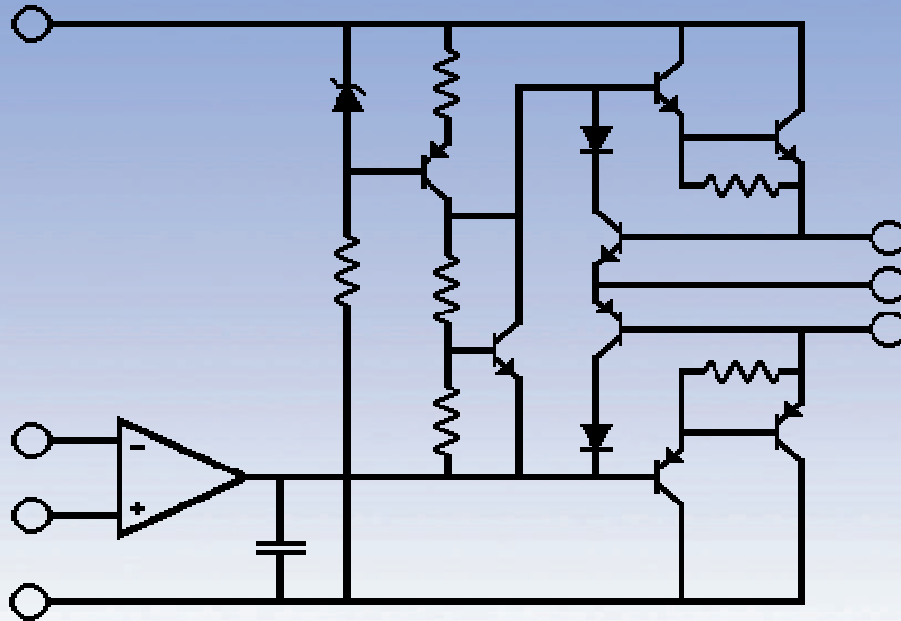

The class “AB” output keeps some current flowing in the output transistors at all times to minimize crossover distortion. This area is still the largest contributor to total harmonic distortion but the “dead” band is gone.

The circuit is known as a  $V_{be}$  or  $V_{gs}$  multiplier. Think of this transistor as a non-inverting op amp with the  $V_{be}$  ( $V_{gs}$ ) as an input and two about equal input and feedback resistors. If the multiplier transistor and the output transistors are tightly thermally coupled, distortion can be kept low and the possibility of thermal runaway is eliminated. This is one area where the hybrid really shines over a discrete circuit because these transistors are physically and thermally close to each. Many Apex amplifiers also use thermistors to compensate for tracking differences due to the transistors being different types. Imagine the tracking differences when the multiplier and power transistors are in separate packages.

We refer to this as a simple amplifier because of the monolithic driver stage which may incorporate 50 to 100 transistors on a single chip.

## Op Amp With Class AB Output Stage

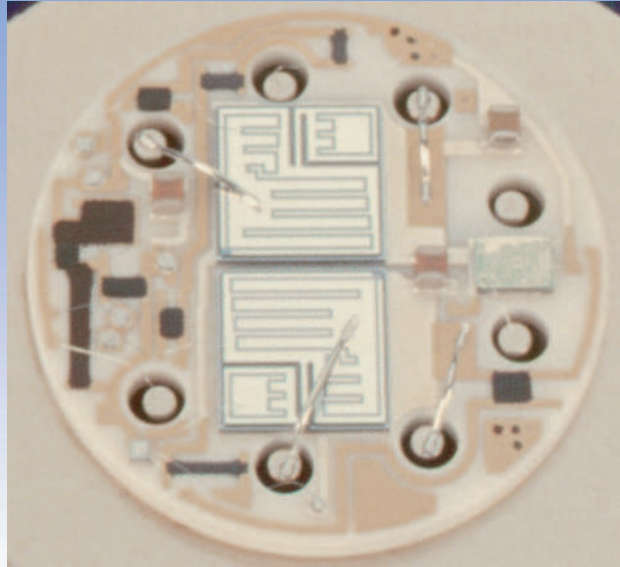

The black areas are thick film resistors which are very cost effective because many resistors can be screened on a single pass and they require no wire bonding. Their intimate contact with the substrate makes them run cool. Wire size here jumps to 10 mils. On higher current products we also use 15 and 20 mil wire.

# Complex Amplifier

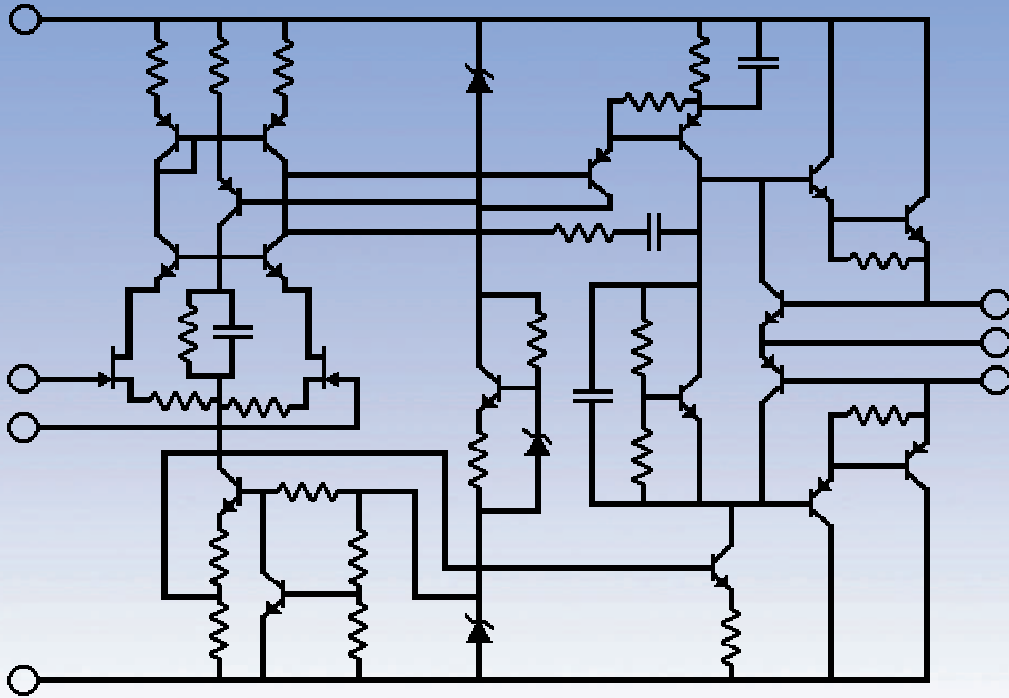

Here is the most difficult and costly way to build a power op amp. Monolithic driver candidates are often lacking in performance above  $\pm 15\text{V}$  and above  $\pm 40\text{V}$  the picture is down right discouraging.

Being able to select each individual transistor for optimum overall performance of the power op amp results in DC accuracy under  $1\text{mV}$ , speeds to  $1000\text{V}/\mu\text{s}$  or total supply voltages to  $1200\text{V}$ .

## Complex Amplifier

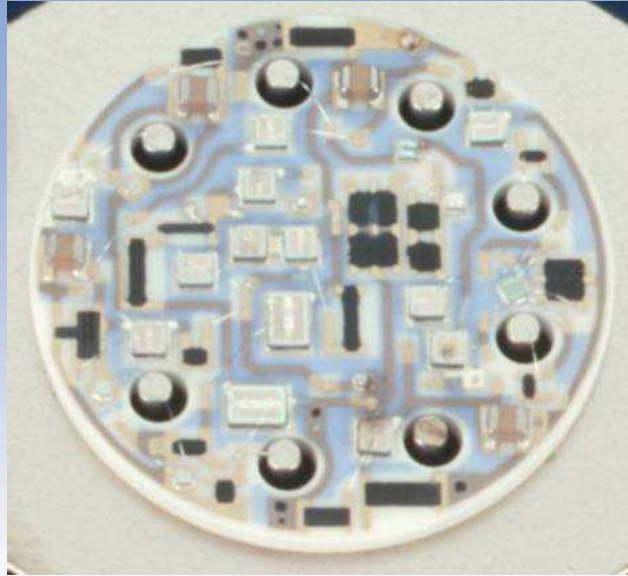

Real estate is at quite a premium with the complex designs. The only new thing added here is the blue glass layer covering most of the conductor traces. It has a two fold purpose: It is a bonding aid and an electrical insulator. This model happens to be a 450 volt part.

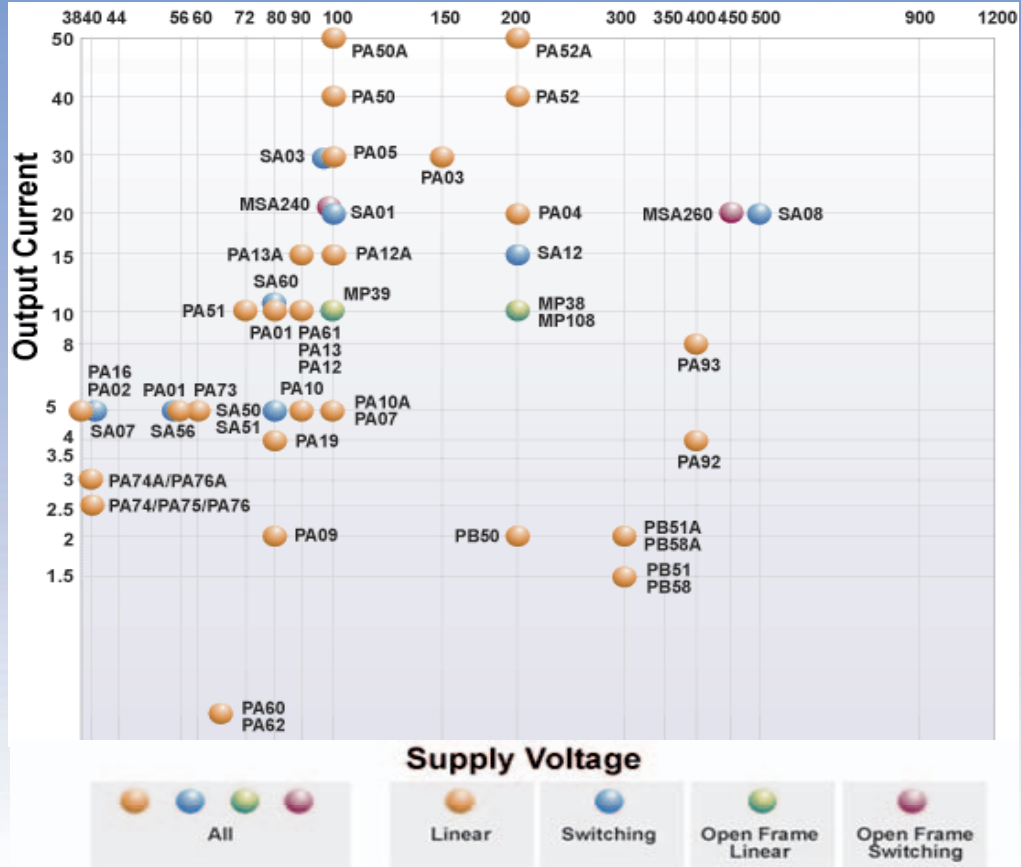

From the plastic packaged PA75 for USD\$4.25 @1K to the PA03A for USD\$853 @1pc, Apex covers a very wide spectrum of multiple ampere models. Typical power response ranges from 13KHz to 3.5MHz.

Data as of April 2005

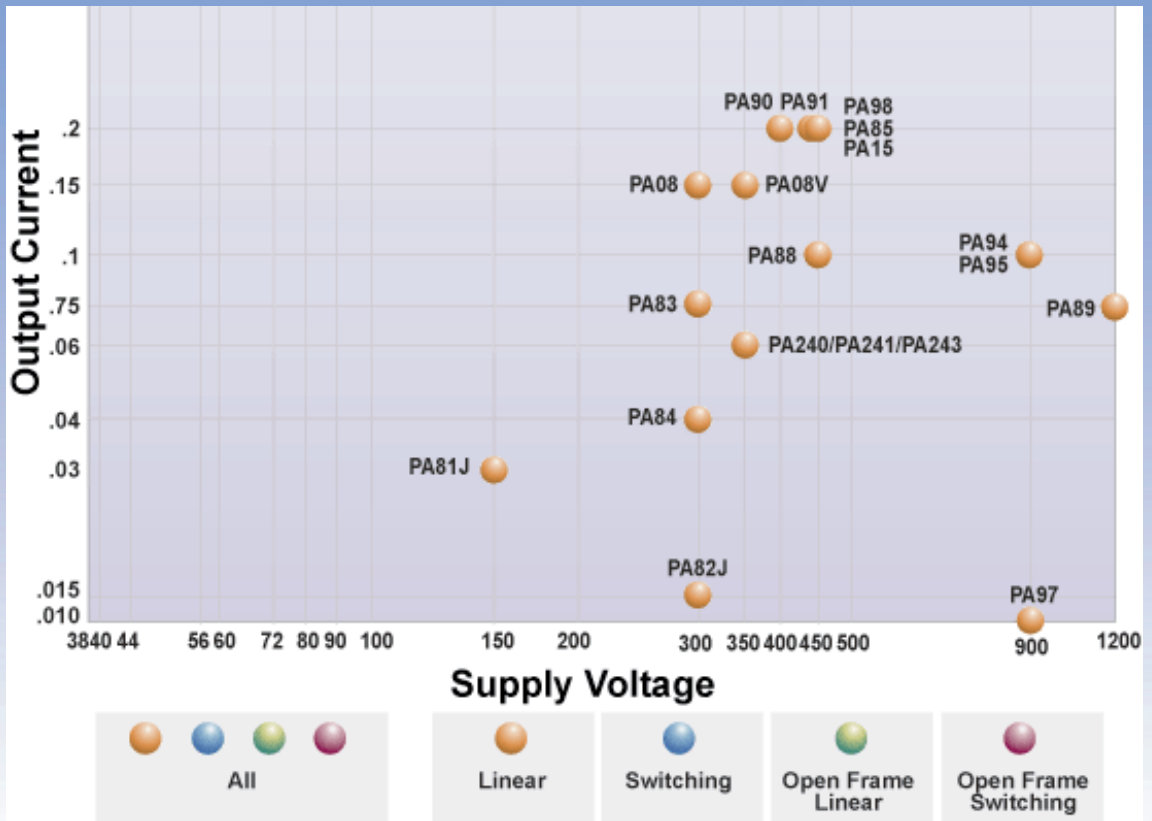

You are looking at the widest selection of high voltage op amps anywhere. From the surface mount PA240CC for USD\$11.55 @1K to the PA89A for USD\$853 @1. Typical power response ranges from 5KHz to 500KHz.

Data as of April 2005.

# Model Selection (PowerDesign Spreadsheet)

	A	B	C	D	E	F	G	H	I	J	K	L	M	N	O	P	Q	R	
1	Part Selection						Read Me			Slew rate to Frequency conversion:									
2	Most positive peak output				75	Volts				Slew rate	130	V/us							
3	Most negative peak output				-75	Volts	Show me the best Amplifier			Frequency	275.86857	KHz		To the right: Washers, sockets, cage jacks, recommended V <sub>s</sub> , typ slew rate					
4	Output current				11	Amps													
5	Frequency				1	KHz			Slew rate =	0.47	V/us								
6	DUAL																		
	Model	V <sub>ss</sub> Min	V <sub>ss</sub> Max	I <sub>out</sub> Continuous Max A	V <sub>drop</sub> (Saturation V)	Common Mode V	Power Bandwidth KHz Typ	I <sub>q</sub> mA Max	Int. Power W Max	Pkg Style	1-24 Qty Price USD Domestic	Voltage Offset mV max	V <sub>os</sub> Drift uV/C Max	Eval Kit Sold Separately	Amplifier Type	Current Limit	Thermal Shut-down	Thermal Washer	
7																			
8	MSA240	3	100	20	2.8		5.0	78	250	KC 58 pin	\$ 133.95	9		EK56	PWM Full	Adjust	No		
9	MP240FC	30	200	20	9.2	15	31.8	25	170	FC	\$151.50	5	50	EK52	Op Amp	Adjust	No		
10	MP240FC+Vb	6	200	20	3.3	15	31.8	25	170	FC	\$151.50	5	50	EK52	Op Amp	Adjust	No		
11	MSA260	3	450	20	3.6		5.0	20	250	KC 58 pin	\$ 193.35	9		EK56	PWM Full	Adjust	No		
12	PA04	30	200	20	8.0	8	54.1	90	200	CR (MO-127)	\$ 315.00	10/5	50/30	EK04	Op Amp	Adjust	No	Tv05	
13	PA04+Vb	6	200	20	5.5	8	54.1	90	200	CR (MO-127)	\$ 315.00	10/5	50/30	EK04	Op Amp	Adjust	No	Tv05	
14	SA01	16	100	20	4.8		4.2	78	185	DE (PD10)	\$ 452.35	10		EK01	PWM Full	Adjust	Yes	Tv10	
15	PA52	24	200	40	7.0	12	106.1	36	400	CR (MO-127)	\$ 557.70	10/5	50	EK27	Op Amp	None	No	Tv05	
16	PA52+Vb	6	200	40	1.6	12	106.1	36	400	CR (MO-127)	\$ 557.70	10	50	EK27	Op Amp	None	No	Tv05	
17	SA18	16	450	20	1.9		2.3	45	125	CR (MO-127)	\$ 562.40			EK18	PWM Half	Special	Yes	Tv05	
18	SA12	16	200	15	7.7		20.0	200	250	CR (MO-127)	\$ 604.95			EK17	PWM Full	Adjust	Yes	Tv05	
19	SA03	16	100	30	3.1		2.3	73	300	CR (MO-127)	\$ 646.90			EK03	PWM Full	Adjust	Yes	Tv05	
20	SA08	16	450	20	3.8		2.3	90	250	CR (MO-127)	\$ 718.60			EK15	PWM Full	Adjust	Yes	Tv05	
21	PA52A+Vb	6	200	50	1.3	12	106.1	36	400	CR (MO-127)	\$ 725.05	5	50	EK27	Op Amp	None	No	Tv05	
22	PA03	30	150	30	5.1	10	17.0	300	500	CU (MO-127)	\$ 656.25	210/5	30H0	EK09	Op Amp	Fixed	Yes	Tv05	
23	MP38CL	30	200	10	9.1	15	21.2	24	125	CL	\$ 71.05	10	50	EK59	Op Amp	Adjust	No		
24	MP38CL+Vb	6	200	10	7.3	15	21.2	24	125	CL	\$ 71.05	10	50	EK59	Op Amp	Adjust	No		
25	MP108FD	30	200	10	10.2	15	360.8	65	100	FD	\$ 127.20	5	50	EK57	Op Amp	Adjust	No		
26	MP108FD+Vb	6	200	10	5.6	15	360.8	65	100	FD	\$ 127.20	5	50	EK57	Op Amp	Adjust	No		

Amplifier requirements have been entered into the yellow cells and the command button used to calculate suitability and sort by cost. For each parameter, the suitability ratio is 1 if the product meets (or exceeds) the requirements or is equal to requirement/capability. The sum of the ratios is used to sort the list.

In this example we see both switching and linear solutions meeting all the application requirements spanning more than a 5.5:1 price range. V<sub>ss</sub> min and max are data sheet specifications while +V<sub>s</sub> and -V<sub>s</sub> are estimations of supply requirements for this specific application (accounts for V<sub>drop</sub> or Saturation Voltage at the application output current). Note the blank cells where parameters do not apply to PWM amplifiers.

Here we find the MSA240 is the “best” choice. However, the selection process knows nothing about noise tolerance of the application, space and weight limitations for heatsink and filter inductors, duty cycle of the output signal, accuracy requirements, military screening needs or - - - . This is a good tool, but we still need an engineer to complete the job.

Even though Dilbert would have a fit, we may even find that talking to marketing would be a good idea. Note the last few lines where the output current spec is shaded green because the amplifiers do not meet the application requirements. This indicates we may be able to reduce cost 2:1 if the output current specification could be reduced only 10%!

# Apex Naming Conventions

• AAAA NNN CC M –or/ NN

Product Family

Product Numbers

Package Characters

Grade Character

Custom Indicator

Custom Number

- Power Op Amp
  - PA98 – Hybrid
  - MP38CL – Open Frame
- Switching Amplifier (PWM)
  - SA60 – Hybrid
  - MSA240KC – Open Frame
- Power Booster
  - PB58 – Hybrid

The overall naming convention for naming new products was adopted in mid-2002. There will always be at least two alpha and two numeric characters plus two more alpha to define the package. The remaining characters are all optional. The most common grade characters are:

The “A” suffix indicates electrical grade out for improved DC accuracy and sometimes voltage capability, temperature range or speed.

The “M” suffix indicates a part with identical design to the standard but with hi-rel screening added. Various models are offered as non-compliant (Apex verified), /883 (government verified) or SMD (government verified and controls the drawing).

The PA and MP power op amps are indeed operational amplifiers following all the rules for these basic building blocks where in a properly designed circuit, performance is controlled by feedback rather than op amp parameters.

The PB power boosters are a unique cost effective solution providing a programmable gain from 3 to 25 at voltages up to  $\pm 150V$  and up to 2A. They are usually configured as the power stage of a composite amplifier which then acts like a power op amp. With the front end of the composite being a low cost typically  $\pm 15V$  op amp, speed and accuracy are easily tailored to need of the application.

The SA and MSA PWM amplifiers come to the rescue when internal power dissipation gets out of hand with linear devices. They provide one full bridge or one half bridge per package.



## ELECTRICAL LIMITATIONS

### EFFECTS ON THE AMPLIFIER

- Slew Rate Limiting
- Output Saturation
- Current Limiting
- Shut Down
- Common Mode Requirements

Power amplifiers and small signal op amps share many limitations. Understanding the limitations of a standard op amp will help you design more accurate, reliable circuitry. It helps to have a good understanding of what happens to an amplifier when it operates outside of its linear region. Most of these electrical limitations can be traced to this common denominator.

# NON-LINEAR OPERATION

## OPEN LOOP MODEL

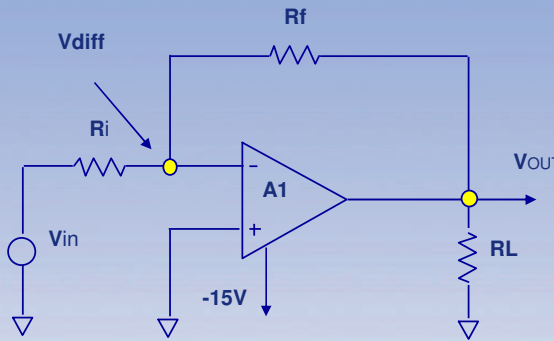

CLOSED LOOP

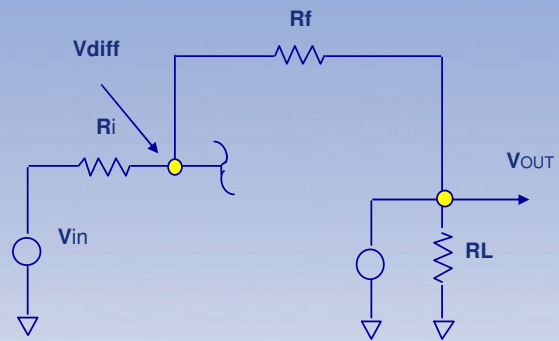

OPEN LOOP

When an amplifier is operated in a closed loop it exhibits linear behavior. A violation of any of the limitations mentioned earlier will effectively open the loop. Once the loop is opened,  $V_{in}$  and  $V_{out}$  appear as two independent voltage sources.  $R_f$  and  $R_i$  function as a simple voltage divider between the two resistors. This voltage appears as a differential input voltage. In cases where the output stage is in a high impedance state, such as power off or thermal shutdown,  $V_{out}$  goes away and  $V_{in}$  is divided down by the series combination of  $R_{in}$ ,  $R_f$  and  $R_{load}$ .



## NON-LINEAR BEHAVIOR

### SLEW RATE LIMIT

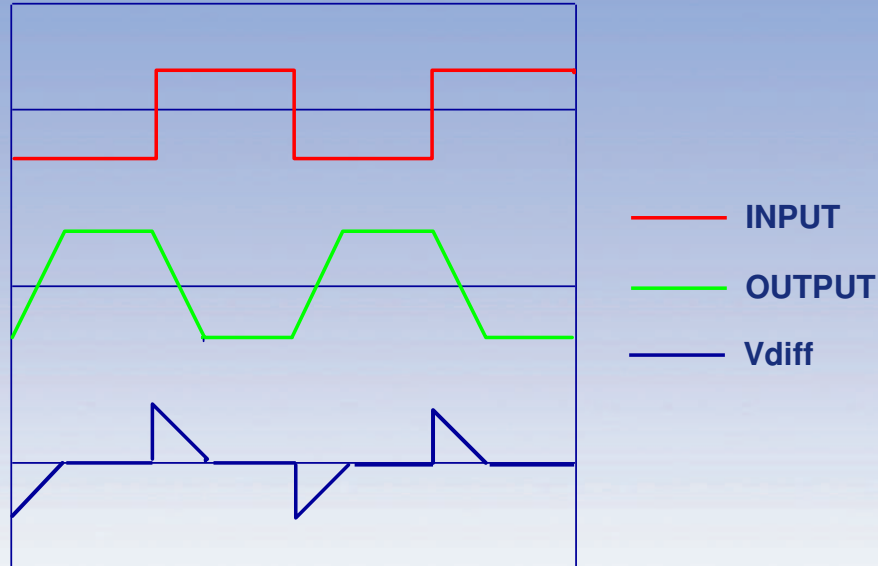

The effect of operating the amplifier in the slew limited region can be seen most dramatically by applying a step voltage to the input. Since the output of the amplifier cannot keep up with an infinite  $dV/dt$ , it goes into slew limited mode and begins changing its output voltage. At the point the amplifier goes into slew limit, we can use our "disappearing op amp" model to visualize what happens at the inverting input node of A1. In the example above, at  $t=0+$ , the input voltage has changed from +10 volts to -10 volts, but the output voltage has not yet changed from -10 volts. Therefore, -10 volts will be on both sides of the divider comprised of  $R_F$  and  $R_I$ . Since there is no voltage difference, the full -10 volts will appear as  $V_{DIFF}$ . As the output tries to "catch up", the right side of the divider will be changing linearly to +10 volts, therefore the differential voltage will drop linearly until the output catches up with the input. When the output catches up, the loop is closed and the differential voltage is zero.

## NON-LINEAR BEHAVIOR

OUTPUT SATURATION & CURRENT LIMIT

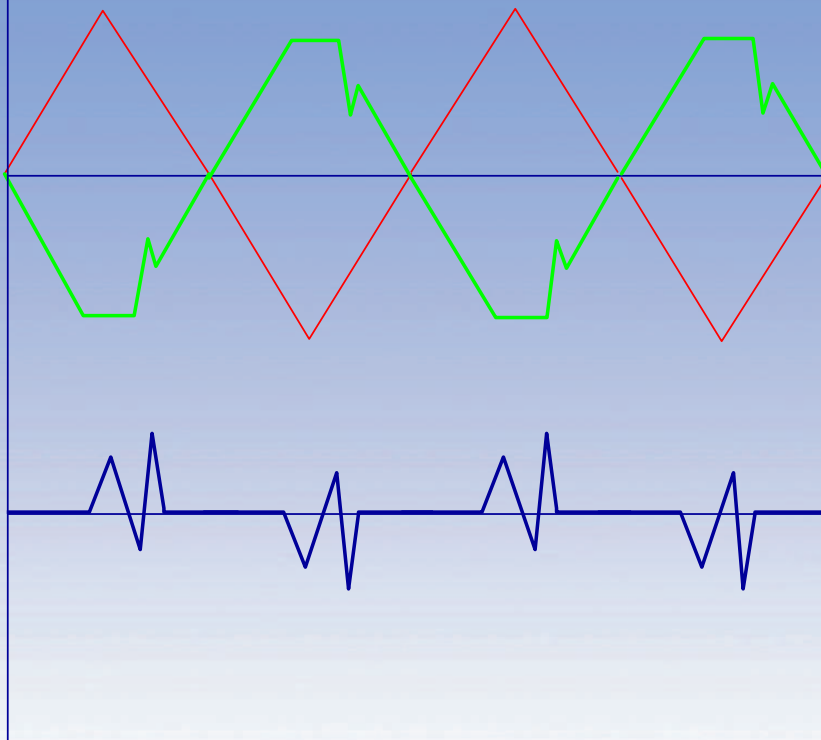

— INPUT  
— OUTPUT  
— Vdiff

Output saturation and current limit exhibit similar behavior — clipping on the amplifier output. This clipping produces differential input voltages.

Any type of clipping can result in an overdriven condition internal to the amplifier. This can lead to recovery problems ranging from simple long recovery to ringing during recovery.

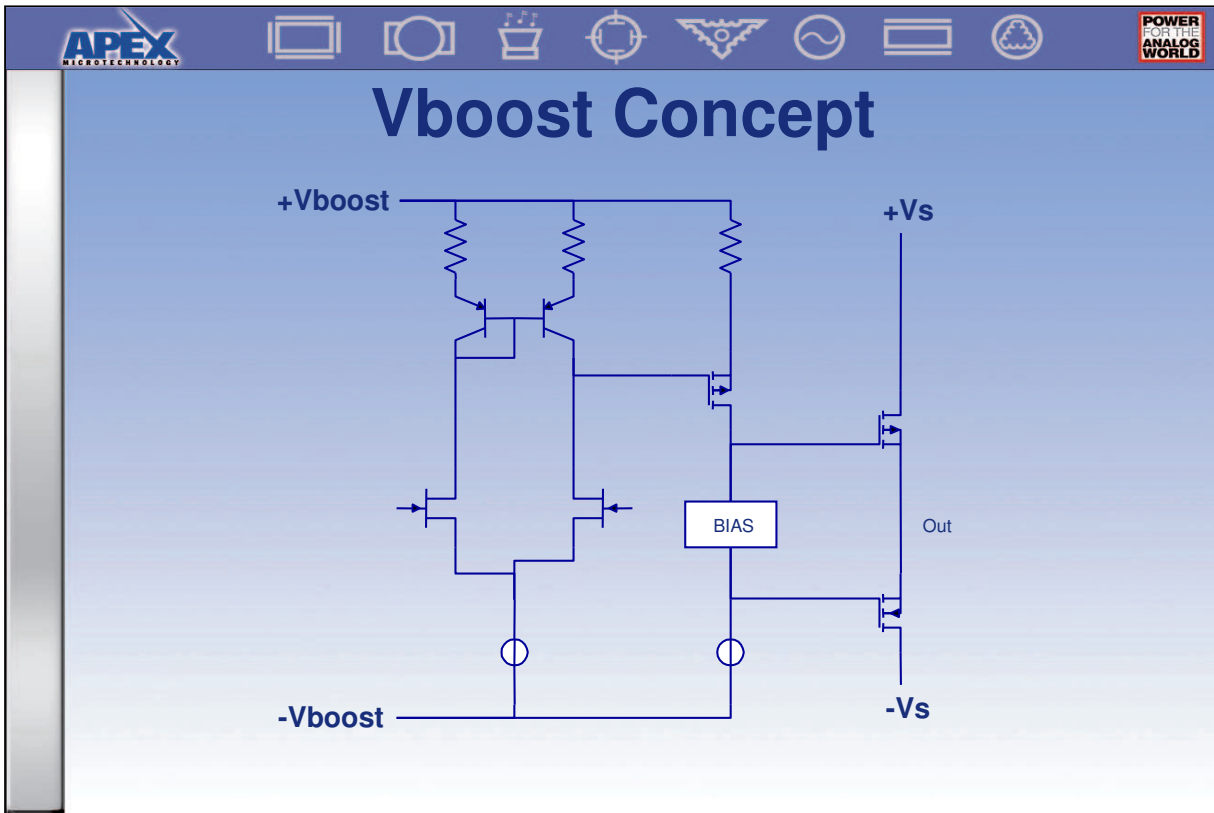

The Vboost concept separates the supplies of the front end, or driver stage, from the supplies of the output stage. When the Vboost supply magnitudes are larger than those of the Vs supplies, the output power MOSFETs can be driven closer to saturation. This allows lower voltages for the high power supply for a given output voltage requirement, thus increasing efficiency and reducing heatsink requirements.

Additionally, the higher Vboost voltages allow a wider range of common mode voltage on the inputs. This can be especially valuable when paralleling amplifiers.

While the Vs supplies will be rated for many amperes, it is rare that the Vboost supplies need to be rated over 100mA.

This is especially true of asymmetrical supply circuits with reactive loads - discussed in more detail later in the presentation. Consider a capacitive piezo drive circuit with symmetric slew rates that drives from 0-100V. Traditional asymmetric supplies might be -15 and 115V. In order to charge and discharge the capacitance symmetrically, these supplies need to be rated for the full current. With the Vboost feature, the -15V can be applied to -Vb and -Vs is tied directly to GND, still allowing an output voltage of 0-100V. -Vb need only to be rated for the input stage Iq of the amplifier.

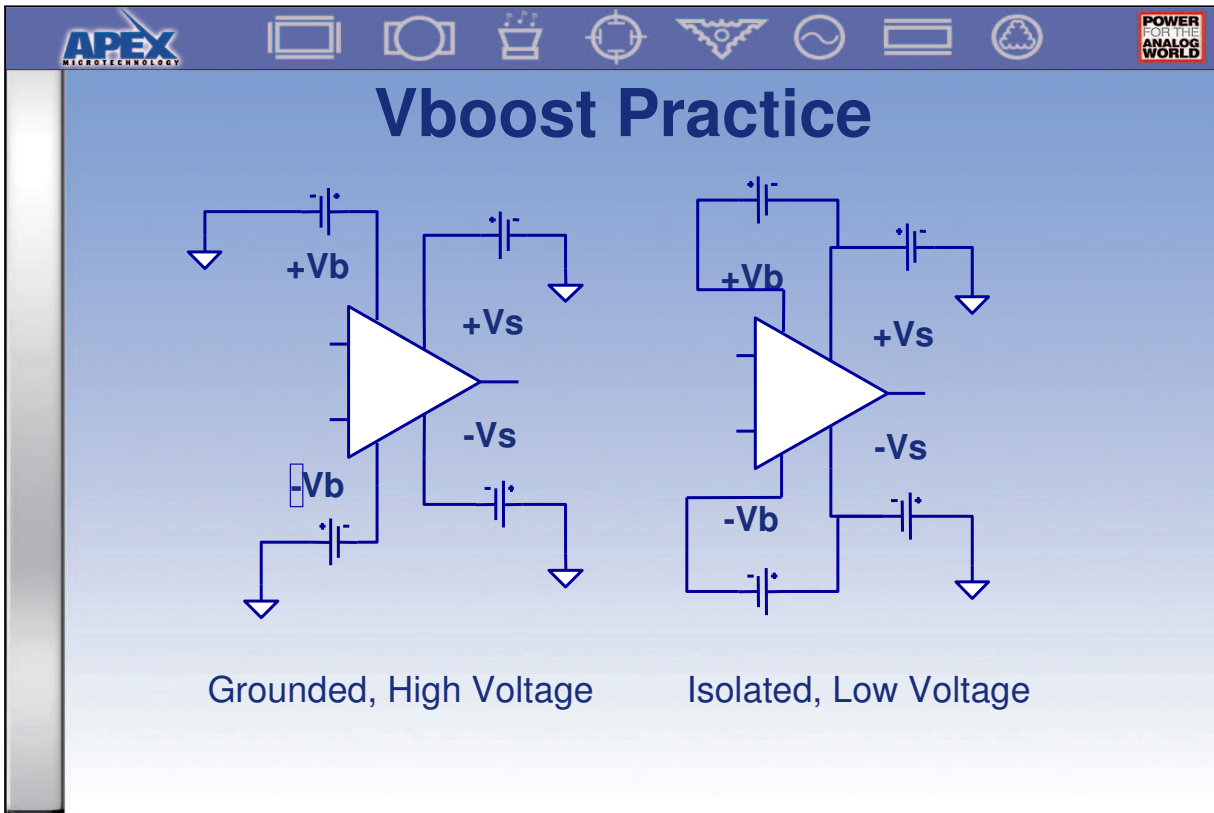

On the left, we see simple ground referenced Vboost supplies which are 5 to 20V larger in magnitude than the Vs supplies. While these supplies do not carry the multiple ampere output currents, they do need to support amplifier quiescent current.

On the right, the Vboost still needs to supply amplifier quiescent current, but with voltage ratings of only 5 to 20V, the wattage requirement will be substantially lower than the ground referenced topology. Sometimes, truly isolated supplies will be used, but converter circuits tied directly to the Vs supplies are very common.

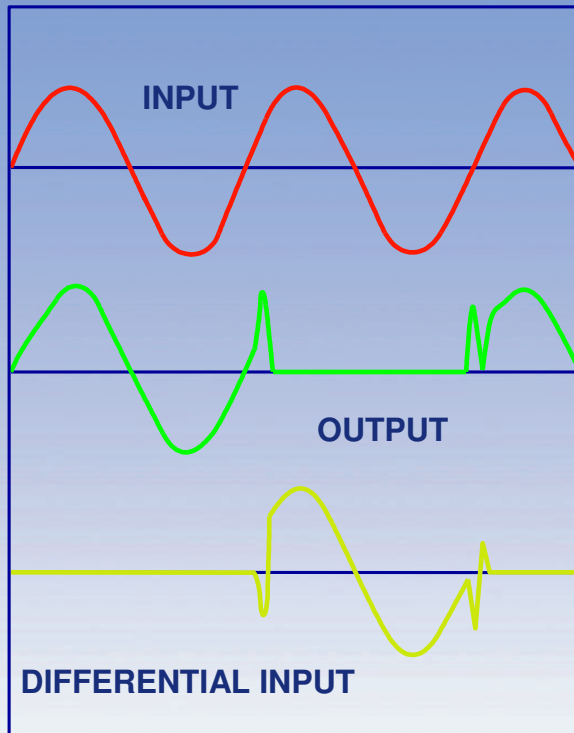

## NON-LINEAR BEHAVIOR

THERMAL SLEEP MODE

The situation with sleep mode is similar to thermal shutdown. In both cases, the amplifier is disabled by some circuitry which results in the output going into a high impedance state. One additional caution is that when coming out of sleep mode, an amplifier may saturate to one of the rails before recovering.

# NON-LINEAR OPERATION

## DETECTING PROBLEMS

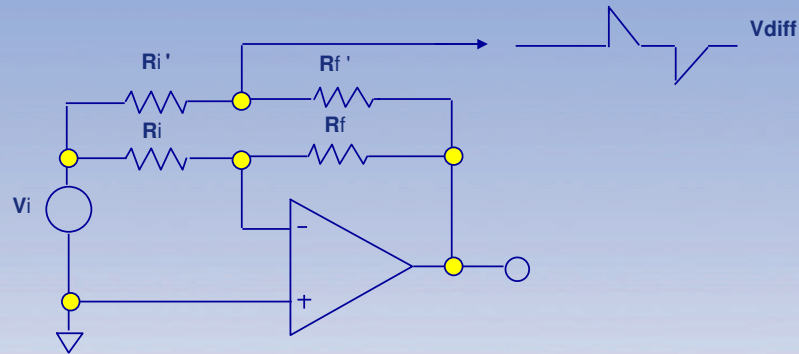

## FALSE SUMMING NODE TECHNIQUE

The common denominator of all non-linear modes of operation is the appearance of differential input voltages. One method of sensing when an amplifier is in a non-linear region is to use this false summing node technique.

If  $Rf'/Ri' = Rf/Ri$ , then  $V_{diff}$  equals the voltage at the inverting node of the amplifier. This buffered error voltage signal can be used as an error flag possibly to drive a logical latch that could shut down the system.



## ABS Maximums vs. the Spec Table

- ABSOLUTE MAXIMUM RATINGS
  - Stress levels, applied one at a time, will not cause permanent damage.
  - Does NOT guarantee op amp performance
- SPECIFICATIONS
  - Linear operation ranges
  - Vos, Ib, drift, CMRR... guaranteed performance

Beware that one stress level may bring on a second, which calls off all bets on op amp survival. Consider a commercial part where the last line of the specification table called "TEMPERATURE RANGE,case" is listed as -25/+85°C. Even though the ABS MAX temperature is 125°C, the part may latch up (very large voltage offset) at 86°C. With loads such as DC coupled inductors this may also lead to violation of the SOA.

Ref. AN1

# Datasheet, page 2

## MP108FD

### ABSOLUTE MAXIMUM RATINGS SPECIFICATIONS

#### ABSOLUTE MAXIMUM RATINGS

SUPPLY VOLTAGE, $+V_S$ to $-V_S$	200V
SUPPLY VOLTAGE, $+V_B$	$+V_S + 15V^{\#}$
SUPPLY VOLTAGE, $-V_B$	$-V_S - 15V^{\#}$
OUTPUT CURRENT, peak	12A, within SOA
POWER DISSIPATION, internal, DC	100W
INPUT VOLTAGE	$+V_S$ to $-V_B$
TEMPERATURE, pin solder, 10s	225°C.
TEMPERATURE, junction <sup>2</sup>	150°C.
TEMPERATURE RANGE, storage	-40 to 105°C.
OPERATING TEMPERATURE, case	-40 to 85°C.

#### SPECIFICATIONS

PARAMETER	TEST CONDITIONS <sup>1</sup>	MIN	TYP	MAX	UNITS
<b>INPUT</b>					
OFFSET VOLTAGE			1	5	mV
OFFSET VOLTAGE vs. temperature			20	50	$\mu V/^{\circ}C$
OFFSET VOLTAGE vs. supply	Full temperature range			20	$\mu V/V$
BIAS CURRENT, initial <sup>3</sup>				100	pA
BIAS CURRENT vs. supply				0.1	$pA/V$
OFFSET CURRENT, initial				50	pA
INPUT RESISTANCE, DC			$10^{11}$		$\Omega$
INPUT CAPACITANCE			4		pF
COMMON MODE VOLTAGE RANGE				$+V_B - 15$	V

Absolute Maximum specifications are found at the top of the second page of every Apex datasheet. Guaranteed specifications can be found below the absolute max specs.

# COMMON MODE VIOLATIONS

GIVEN: PA02  $V_{cm}$  RANGE =  $\pm |V_s - 6|_R$

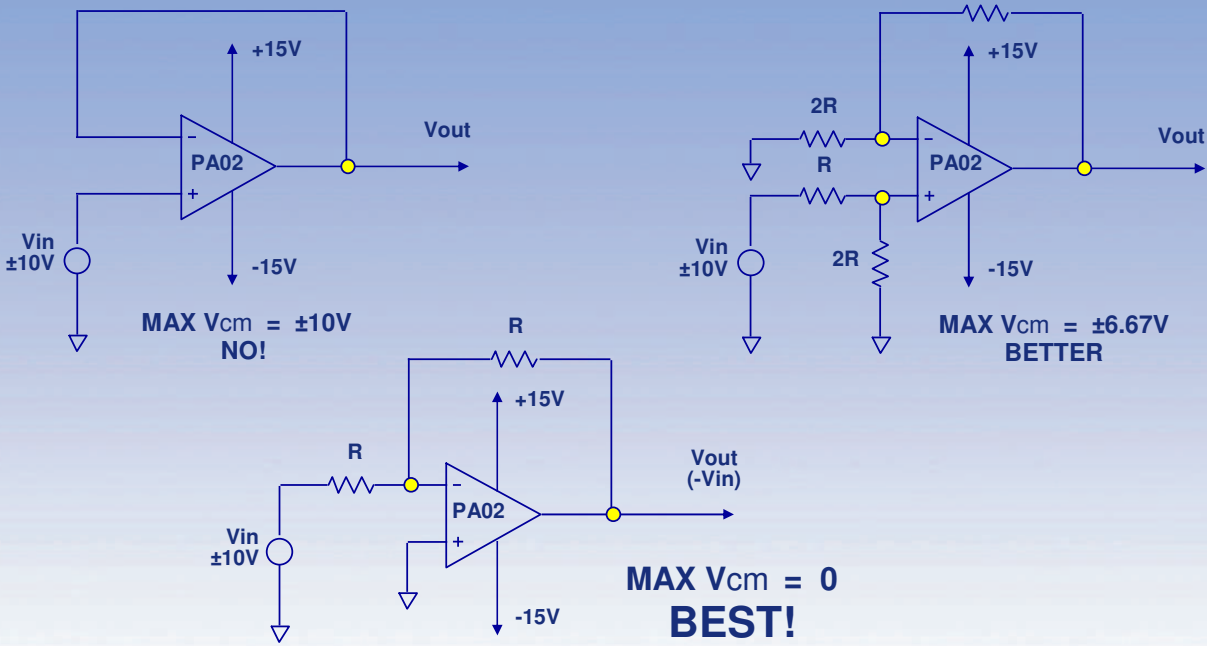

In an inverting configuration, the op amp's non-inverting terminal is usually tied to ground, making the inverting terminal a "virtual ground." This results in zero common mode voltage: a desirable benefit. However, operating the amplifier in a non-inverting mode results in the common mode voltage being equal to the voltage at the non-inverting terminal.

The schematics above illustrate the problem. The amplifier used in this example cannot have any common mode voltage that approaches within 6 volts of either supply rail. The first example shows a unity gain follower. This is the configuration where common mode violations are most common. Note that the input voltage is equal to the common mode voltage. In our example the input voltage exceeds the common mode range.

In the second example the input signal is first attenuated and then gained back up to result in a lower common mode voltage but a unity gain non-inverting transfer function. That is:

$$V_o = V_i(2R/(2R+R))(1+R_f/R_i)$$

where  $R_f = R$  and  $R_i = 2R$

The third example shows the best approach to eliminating common mode violations: use inverting configurations. In this case the input voltage is still 10 volts, the output voltage is 10 volts, but the common mode voltage is zero, eliminating the problem. Of course this does invert the phase of the output signal.



## AMPLIFIER PROTECTION ELECTRICAL

- Input Transients
- Output Transients
- Over-voltage

## WHY DIFFERENTIAL INPUT PROTECTION?

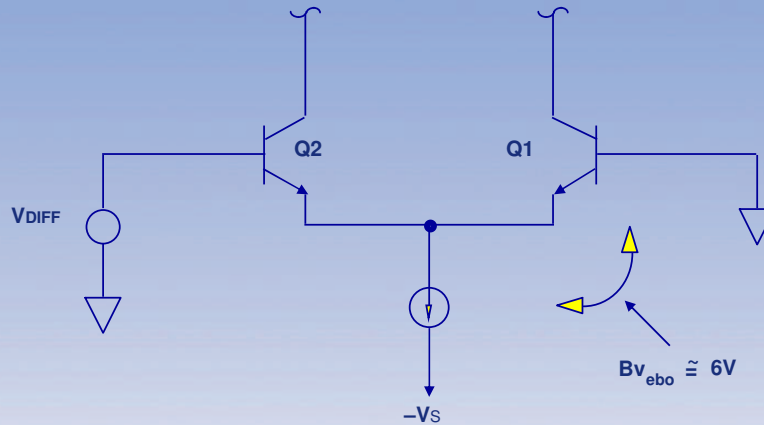

### WHY DIFFERENTIAL INPUT PROTECTION?

Simple, to avoid damaging input stages due to differential overvoltage. Any input stage has maximum differential limits that can be exceeded any number of ways, with the most subtle occurring during non-linear operation.

In amplifiers with bipolar inputs, such as a PA12, differential overvoltage has the additional hazard of causing degradation without catastrophic failure. Exceeding the reverse-bias zener voltage of a base-emitter junction of a transistor used in a differential amplifier can permanently degrade the noise, offset, and drift characteristics of that junction.

# INPUT PROTECTION

## DIFFERENTIAL

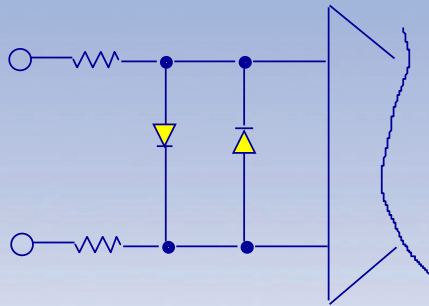

**SIMPLE**

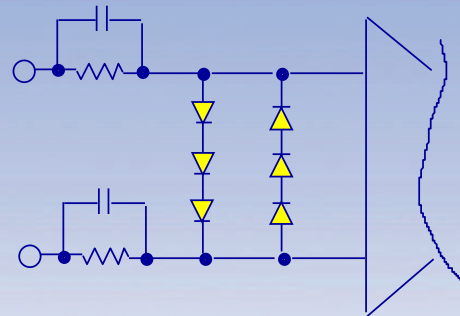

**ALLOWS OVERDRIVE**

The protection scheme on the left uses parallel diodes to limit the differential voltage and uses series resistors to limit the current that flows through the diodes. The slightly more complicated scheme on the right accomplishes the same thing, but by using stacked diodes, allows a higher differential voltage to be developed. This allows a greater slew rate overdrive. The capacitors perform a similar function by allowing high frequency information to be passed directly to the input terminals.

Ref. AN1 AMPLIFIER PROTECTION AND PERFORMANCE LIMITATIONS

AN25 HIGH VOLTAGE AMPLIFIER SUPPORT COMPONENTS

# GAIN SWITCHING

DON'T GET BURNED!

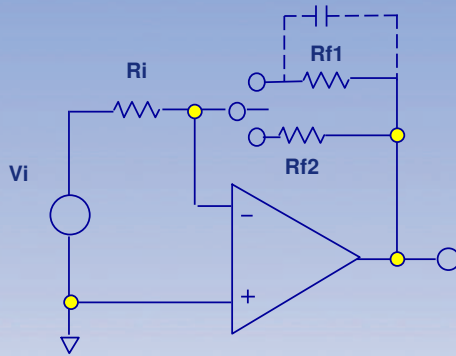

**BAD**

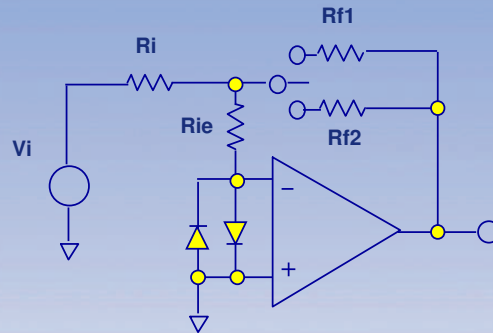

**BETTER...**

Often it is a requirement that the gain of an amplifier be switchable. This is very common in ATE applications. One method of doing this is shown on the left. This is a very poor way to accomplish gain switching. The problem is that the amplifier is usually much faster than the relay used to switch between the two resistors. **WHEN THE RELAY OPENS, THE AMPLIFIER HAS NO FEEDBACK.** Since the amplifier is now open loop, the amplifier will immediately slew toward one of the supply rails. By the time the relay closes, the amplifier will be saturated and the output voltage will appear directly at the inverting terminal of the amplifier.

The method on the right does not solve the problem, but it does provide amplifier protection. The parallel diodes clamp the differential input voltage while  $R_{ie}$  limits the amount of current that can flow during transient conditions. The value of  $R_{ie}$  should be chosen to limit the current to approximately 15mA with one full supply voltage across the resistor.

Ref. AN1 AMPLIFIER PROTECTION AND PERFORMANCE LIMITATIONS

## GAIN SWITCHING

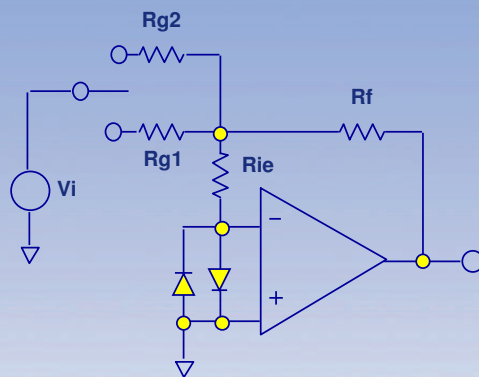

**GOOD**

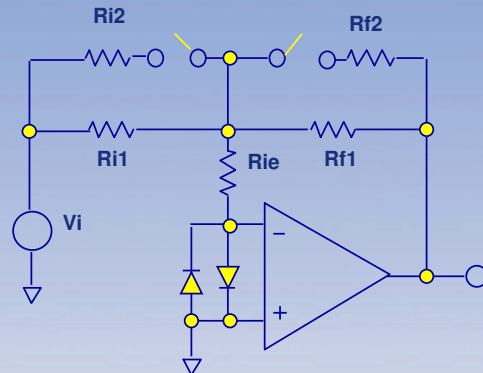

**BEST**

The "good" approach above represents a vast improvement over the previous technique. In this approach, gain is switched by switching the value of the input resistors rather than the feedback resistor. The major advantage to this approach is that the feedback loop is kept closed at all times. When the relay opens, the amplifier is now a unity gain follower with a zero volt input. The most voltage that will appear at the output is the offset of the amplifier. Input protection is still shown in this configuration to protect against possible switching transients.

The "best" approach above shows a configuration that prevents switching inside the feedback loop or opening up the input loop.  $R_{i1}$  and  $R_{f1}$  are in place at all times. The gain of the circuit is switched by EITHER switching in  $R_{i2}$  to parallel  $R_{i1}$  OR by switching in  $R_{f2}$  to parallel  $R_{f1}$ . This approach eliminates any transient voltages due to relay switching. At the time of contact closure, only the gain changes. Although input protection is still shown in this schematic, its only function is to protect the input in cases of non-linear operation, such as slew rate or current limit.

Ref. AN1 AMPLIFIER PROTECTION AND PERFORMANCE LIMITATIONS

# INPUT PROTECTION

## OVERVOLTAGE

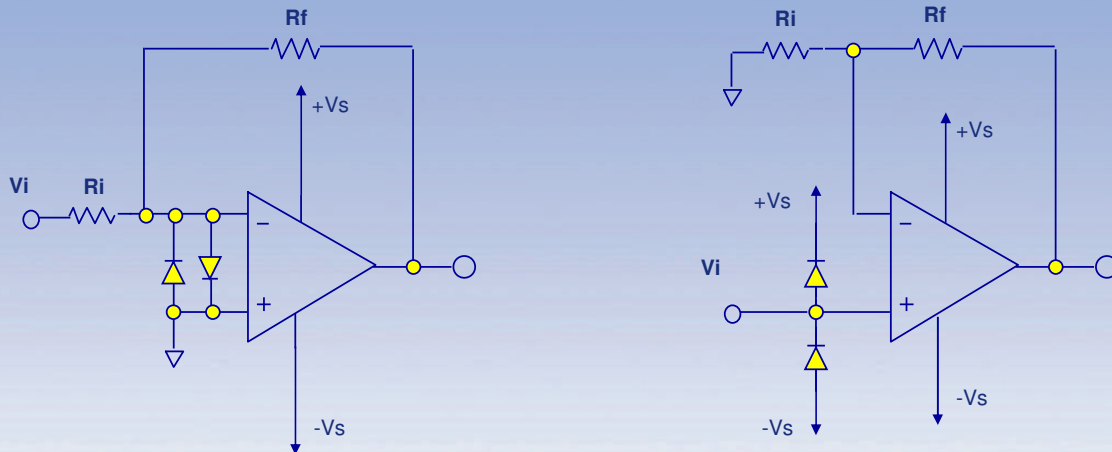

In multiple power supply systems, power supply sequencing is often a problem. If the power supplies for the "driving stage" come up before the "driven stage", the maximum input common mode specification may be violated. The diodes shown in the two circuits above serve to clamp the driven input to the amplifier supply pin so that the input cannot be raised above the supply voltage. Note, however, that if the supplies are in a high impedance state when the power supply is turned off, this approach will not protect the amplifier. Under those conditions however, the inverting amplifier configuration could be protected by running parallel diodes from the inverting node to ground. These would clamp the inverting input to ground under any circumstances. Since the inverting terminal is normally at virtual ground, these diodes would not interfere with signal in any way. However, on the non-inverting amplifier this approach will not work because the non-inverting input sustains a common mode voltage.

Ref. AN1 AMPLIFIER PROTECTION AND PERFORMANCE LIMITATIONS

# OUTPUT PROTECTION

## KICKBACK / FLYBACK

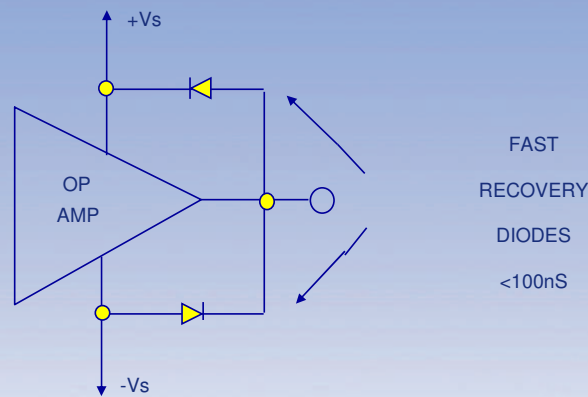

NOTE: SUPPLIES MUST BE ABLE TO ABSORB  
TRANSIENT ENERGY, i.e.: LOW IMPEDANCE

Attempting to make a sudden change in current flow in an inductive load will cause large voltage flyback spikes. These flyback spikes appearing on the output of the op amp can destroy the output stage of the amplifier. DC motors can produce continuous trains of high voltage, high frequency kickback spikes. In addition, piezo-electric transducers not only generate mechanical energy from electrical energy but also vice versa. This means that mechanical shocks to a piezo-electric transducer can make it appear as a voltage generator. Again, this can destroy the output stage of an amplifier.

Although most power amplifiers have some kind of internal flyback protection diodes, these internal diodes SHOULD NOT be counted on to protect the amplifier against sustained high frequency kickback pulses. Under these conditions, high speed, fast recovery diodes should be used from the output of the op amps to the supplies to augment the internal diodes. These fast recovery diodes should be under 100 nanoseconds recovery time; and for very high frequency energy, should be under 20 nanoseconds.

One other point to note is that the power supply must look like a true low impedance source or the flyback energy coupled back into the supply pin will merely result in a voltage spike at the supply pin of the op amp again leading to an over voltage condition and possible destruction of the amplifier.

Ref. AN1 AMPLIFIER PROTECTION AND PERFORMANCE LIMITATIONS

AN25 HIGH VOLTAGE AMPLIFIER SUPPORT COMPONENTS

# AMPLIFIER PROTECTION

## POWER SUPPLY OVERVOLTAGE

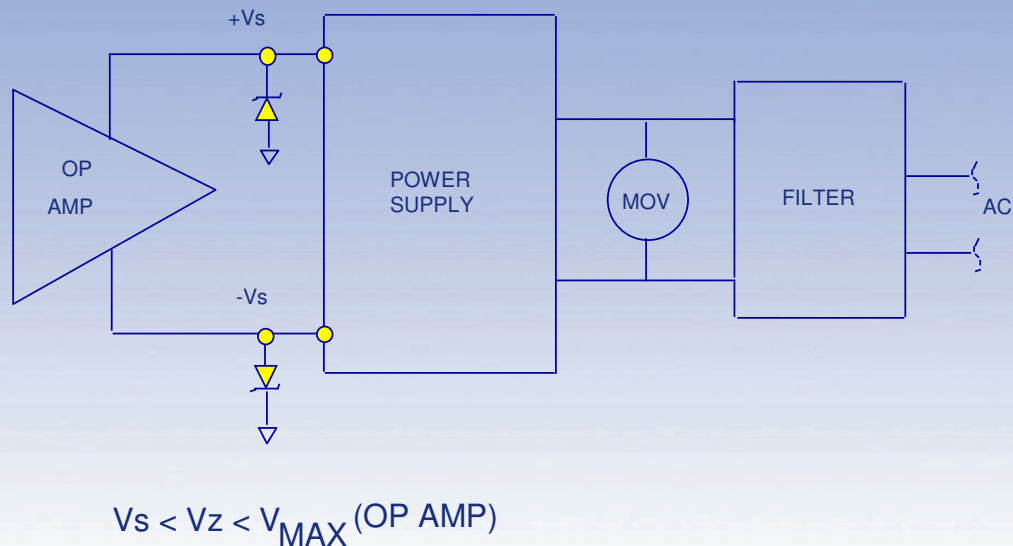

The amplifier should not be stressed beyond its maximum supply rating voltage. This means that any condition that may lead to this voltage stress level should be protected against. Two possible sources are the high energy pulses from an inductive load coupled back through flyback diodes into a high impedance supply or AC main transients passing through a power supply to appear at the op amp supply pins. These over voltage conditions can be protected against by using zeners or transorbs direct from the amplifier supply pins to ground. The rating of these zeners would be greater than the maximum supply voltage expected, but less than the breakdown voltage of the operation amplifier. Note also that MOS's can be included across the input to the power supply to reduce transients before they reach the power supply. Low pass filtering can be done between the AC main and the power supply to cut down on as much of the high frequency energy as possible. Note that inductors using power supplies will pass all high frequency energy and capacitors used in power supply are usually large electrolytics which have a very high ESR. Because of this high ESR, high frequency energy will not be attenuated fully and therefore will pass on through the capacitor largely unscathed.

Ref. AN1 AMPLIFIER PROTECTION AND PERFORMANCE LIMITATIONS

AN25 HIGH VOLTAGE AMPLIFIER SUPPORT COMPONENTS