



DESIGN SOLUTION Analog

Sam Robinson

APEX MICROTECHNOLOGY CORP.

srobinson@apexmicrotech.com

Drive Piezoelectric Actuators With Fast, High-Power Op Amps

Think you can't drive your actuator at 80 kHz with 300-V p-p signals using MOSFET IC op amps? Then try out this bridge configuration.

In the last 15 years, high-speed piezoelectric actuators have become less expensive to manufacture. Consequently, they find themselves as a favorite design choice for a growing number of applications.

Piezoelectric actuators made their initial entry in medical devices, including surgical tools and ultrasonic testing in the late 1980s. It was for good reason. Piezoelectric actuators are the fastest-responding positioning element available with microsecond time constants. They also can produce motions in subnanometer increments. So, it's no surprise to see a dramatic rise in the number of companies designing products that employ these devices.

Piezoelectric actuators require high-voltage drivers that can deliver hun-

dreds of volts, peak-to-peak. In addition, because a typical actuator looks virtually like a pure capacitance to the driving amplifier, nearly all power dissipation becomes the burden of the driving amplifier.

A quick look through the abundance of high-speed, small-signal op amps will disclose many amplifiers with bandwidths in the hundreds of megahertz. But to combine that speed with more than 12 V, as you must if you're planning to drive a high-speed piezoelectric device, the choices of suitable amplifiers shrink pretty fast. Moreover, choosing a design based upon a MOSFET monolithic amplifier has compelling benefits.

The piezoelectric actuator circuit in the example presented here requires a 300-V p-p source at 80 kHz. It will drive

our actuator, which can be represented by a 1-nF capacitance in series with a 1-Ω resistance (Fig. 1).

A LOOK AT THE OPTIONS • We evaluated several alternatives for our application before deciding on the best approach to drive a piezoelectric actuator:

- *Single amplifier:* Cost is the issue with this option. Because a piezoelectric actuator will require a swing between +150 V and -150 V, the only device on the market that meets this requirement at a frequency of 80 kHz is going to be a hybrid, which will price out at over \$100 each.

- *Small-signal amplifier with level shifting:* A design that begins with a small-signal amplifier, followed by level shifting, means configuring a design from scratch with a large number of discretes. In this case, the non-recurring-engineering effort will be large, and the design time will be long and costly.

- *High-voltage, high-speed, low-current MOSFET op-amp IC:* The monolithic PA78, which we chose for this design, uses a class A/B driver stage to drive output MOSFETs and an innovative input stage to achieve very high slew rates—without the high quiescent currents of traditional op-amp designs. Also, this design will require two PA78s. And because this amplifier is an IC design, it will cost approximately \$15 each. That's a considerable savings vis-à-vis the hybrid at over \$100.

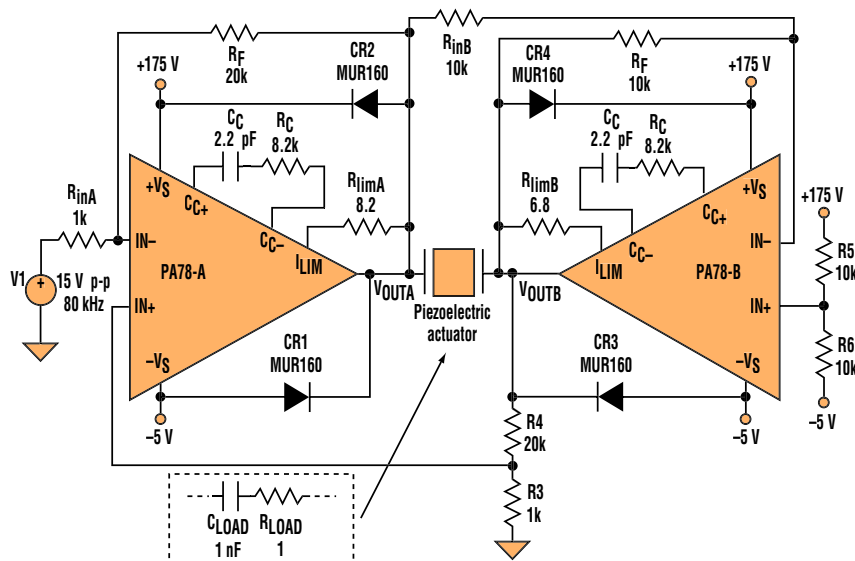

1. This circuit shows a bridge-connected configuration. Two PA78s drive the piezoelectric actuator. Asymmetric power supplies at +175 V and -5 V power the PA78s.

As depicted in Figure 1, we've configured two PA78s in a bridge circuit.¹ In this configuration, the amplifiers supply an output-voltage swing twice that of a

DESIGN SOLUTIONS Analog

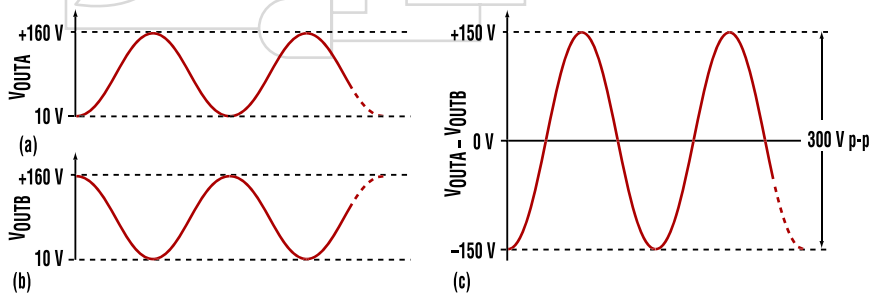

2. These output waveforms show the left module output (a), the right module output (b), and the waveform appearing across the piezoelectric actuator (c).

single op amp. This configuration doubles the slew rate. Any nonlinearities become symmetrical, reducing second-harmonic distortion compared to a single-amplifier circuit.

The sinusoidal source applies 15 V p-p at 80 kHz to drive the amplifier pair, which, in turn, drives the piezoelectric actuator. In our case, we shall assume that the piezoelectric actuator will exhibit an equivalent impedance of a 1-nF capacitor in series with a 1-Ω resistor, as shown.

A FLOATING LOAD • In our application, the load is floating. In other words, it's not ground-connected at all. When the left output V_{OUTA} swings from 10 to 160 V (Fig. 2a) and the right output V_{OUTB} descends from 160 V to 10 V (Fig. 2b), a voltage swing of 300 V (–150 V to +150 V) develops across the load (Fig. 2c).

The outputs of the two amplifiers are now out of phase. The overall gain of the bridge-configured PA78s is +20, so that 300 V p-p is delivered to the piezoelectric actuator, as required. The feedback circuit comprising resistors R3 and R4 center both of the PA78 modules' outputs around 85 V. As shown in Figure 1, a dual-source, asymmetric power supply delivers +175 V and –5 V to the two amplifier modules.²

ESTABLISH +V_S, –V_S HEADROOM

• The values of +V_S and –V_S must be carefully chosen to ensure sufficient headroom during the positive and negative excursions of both V_{OUTA} and V_{OUTB} . The output $V_{OUTA} - V_{OUTB}$ will swing from +150 V to –150 V.

But it's the amplifier's common-mode input range (CMR) positive and negative values (specified in the PA78 data sheet) that play a significant role in governing the values of +V_S and –V_S in this asymmetric sourcing arrangement.

In the case of the PA78, the specified value of the CMR negative is –V_S + 3 V. This means the input should approach the negative rail no closer than 3 V. Therefore, by choosing –V_S equal to –5 V, both V_{OUTA} and V_{OUTB} (having negative excursions to 10 V) will approach the negative rail no closer than 15 V. With the CMR positive, the value is +V_S – 2 V. This means that the most positive-going excursion of both V_{OUTA} and V_{OUTB} must stay at least 2 V below +V_S.

A second issue with regard to the +V_S rail is the voltage drop at the output when the modules are delivering peak current. In this application, the peak current is approximately 75 mA. A graph in the PA78 data sheet called "Output Voltage Swing" says that if you're driving this much current, you will lose approximately 8 V. The sum of the two, 2 V and 8 V, is 10 V, which says the +V_S must be at least 10 V above our maximum voltage swing of 150 V. Choosing a +V_S of

175 V means an additional headroom margin of 15 V.

With any piezoelectric actuator circuit, it's essential to prevent signals from inadvertently feeding back to the amplifier. A piezo transducer can convert mechanical into electrical energy just as easily as going from electrical to mechanical. So if something were to bump the transducer, it may create lots of energy that would travel backwards into the output of the amplifier. Of course, that could be rather destructive. Yet simply connecting several ultra-fast MUR160 diodes (CR1 to CR4) from the output of each amplifier to its corresponding power-supply rails will protect each amplifier.

COMPUTING THE MAX DISSIPATED POWER PER MODULE

• The load impedance of the piezoelectric cartridge is given by the expression:

$$R + \frac{1}{j\omega C} = 1 + \frac{1}{j2\pi(80 \times 10^3)(1 \times 10^{-9})} = 1 - j1989 \approx -j1989\Omega$$

assuming that R = 1 Ω, C = 1 nF, and ω = 80 kHz.

To compute the maximum power per module, we can devise the equivalent circuit shown in Figure 3. To do this, the Figure 1 circuit is split into two parts, with each part comprising a 2-nF capacitor and a 0.5-Ω resistor, while assuming a virtual ground denoted by the dotted line and symbol. Because the real part of the impedance (1 Ω) is negligible compared with the total capacitive reactance of 1989 Ω, we shall neglect it.

In our equivalent circuit, the applied voltage will be one half the total potential applied to each module:

$$0.5[(+V_S) - (-V_S)] = 0.5[(175 \text{ V}) - (-5 \text{ V})] = 90 \text{ V}$$

The circuit for each half will drive half the capacitive reactance, which is 1989 divided by 2 each, or 994.5 Ω. Determining power dissipation begins with knowing the phase difference between V and I in the load. This is a simple case because we've modeled our load as a pure capacitor, so the phase angle φ is 90°. The formula for determining the maximum power dissipated when there's a reactive load for a phase angle greater

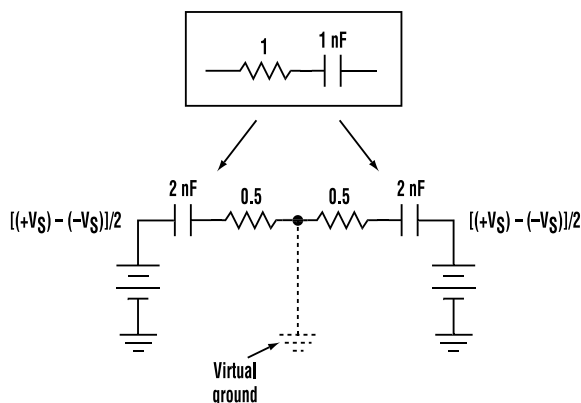

3. Maximum power dissipation is computed using the equivalent circuit shown here.

DESIGN SOLUTIONS Analog

than 40° is given by:³

$$P_D(\max) = \frac{2V_S^2}{\pi Z_L}$$

where V_S is the magnitude of each supply and Z_L is the magnitude of the load impedance.

Therefore,

$$P_D(\max) = \frac{2(90)^2}{\pi(994.5)} = 5.18 \text{ W}$$

Because the load is totally reactive, the 5.18 W are dissipated by each PA78 amplifier IC and none by the load. We can then go on to select a heatsink and confirm that the maximum allowable junction temperature of each PA78 won't be exceeded.

DEALING WITH THE HEAT • An HS27 heatsink has been selected for mounting each PA78 IC. The thermal resistance of each is 5.3°C/W and, as we have determined, the dissipation of each amplifier will be 5.18 W.

We must confirm that the junction temperatures of the MOSFET devices in the PA78 won't exceed a safe value. The familiar thermal resistance equation is:

$$P\theta_{JA} = T_J - T_A$$

$$P(\theta_{JC} + \theta_{CA}) = T_J - T_A$$

We can modify the above equation by substituting the thermal resistance of the heatsink θ_{HS} for θ_{CA} :

$$P(\theta_{JC} + \theta_{HS}) = T_J - T_A$$

We want to solve this for T_J to confirm that we won't exceed the maximum junction temperature. Rearranging the terms, we have:

$$T_J = P(\theta_{JC} + \theta_{HS}) + T_A$$

In our case the power per device is 5.18 W and the θ_{JC} , according to the PA78 data sheet, is 5.5°C/W. The θ_{HS} for the heatsink is 7.8°C/W, and the rise in temperature above the ambient is 48.2°C. (For the graphs that show the heatsink's thermal resistance as a function of power, and the temperature rise at the interface, go to www.elecdesign.com and see *Drill Deeper 11366*.)

Thus, the maximum junction temperature will be:

$$\begin{aligned} T_J &= P(\theta_{JC} + \theta_{HS}) + T_A \\ &= 5.18(5.5 + 7.8) + 25^\circ\text{C} \\ &= 68.9^\circ\text{C} + 25^\circ\text{C} \\ &= 93.9^\circ\text{C} \end{aligned}$$

Therefore, the actual T_J will never rise above 93.9°C. This is far below the maximum permissible value of 150°C specified in the PA78 data sheet.

It's essential when applying high power to a highly reactive load, such as a piezoelectric actuator, to check the dissipation and the safe operating area. The former is discussed in the Application Note "General Operating Conditions,"³ and the latter is covered in the PA78 data sheet.

In the past, industrial-grade power amplifiers have traded off bandwidth to ensure unity-gain stability. Bipolar designs haven't always met the linearity requirements of demanding applications⁴, such as the piezoelectric actuator design in this article. But with the availability of a MOSFET-based architecture in devices, the possibilities have changed. Now new standards for bandwidth and linearity can be created for IC power amplifiers. **ED**

ED Online 11302

Sam Robinson is an applications engineer specializing in power analog electronics at Apex Microtechnology Corp. (www.apexmicrotech.com), Tucson, Ariz. He holds a BSEE from the University of Alabama in Huntsville.

References:

1. Application Note 20, "Bridge Mode Operation of Power Operational Amplifiers," Apex Microtechnology Corp., www.apexmicrotech.com.
2. Application Note 21, Section 3.1, "Single Supply Operation of Power Operational Amplifiers," *ibid*.
3. Application Note 1, Section 7.2, "General Operating Considerations," *ibid*.
4. Application Note 17, "Wide Band Low Distortion Techniques," *ibid*.

